

SKIPPER EML1100 /EML1200

Electromagnetic STW Speed log

Operation and Installation manual



This page is intentionally left blank.

Document revision log				
1.1.0	18.9.2024	Changes for Limited release	PC	PC
X3	29.3.2024	preliminary	PC	PC
Rev	Issue Date (DD.MM.YY)	Reason for Issue	Author	Approval

Safety instructions

**ELECTROSTATIC SENSITIVE DEVICE:**

Important! This equipment contains CMOS integrated circuits. Observe handling precautions to avoid static discharges which may damage these devices.

**HEARING IMPAIRMENT HAZARD:**

Caution! Avoid listening at high volume levels for long periods!

**ELECTRICAL SHOCK HAZARD:**

Warning! Do not open the equipment!
Only qualified personnel should work inside the equipment.

**TOXIC HAZARD:**

Warning! Some RF semiconductor devices used in this equipment may contain Beryllium Oxide. If inhaled, dust from this oxide can be toxic. No danger will arise from normal handling, but no attempt should be made to tamper with these devices. On no account must these transistors be destroyed or discarded with industrial or domestic waste but should be returned to the manufacturer for subsequent disposal or to a suitable destination facility that can safely handle the electronic waste.

Table of Contents

- 1 Introduction 7**
- 2 EML Principle of operation..... 7**
- 3 Terminology 7**
 - 3.1 Units7
 - 3.2 Abbreviations8
 - 3.3 Alert Symbols9
- 4 Physical Installation..... 9**
 - 4.1 Installation of the screen9
 - 4.2 Connection of the system13
 - 4.2.1 General Cabling14
 - 4.2.2 Connecting to the Aux outputs16
 - 4.2.3 Network cables.....16
 - 4.2.4 Cabling to the sensor16
 - 4.2.4.1 Cable Dimensions16
 - 4.2.5 Optional JB40 unit.....17
 - 4.3 Power requirements:17
 - 4.4 Installation of the sensor and metalwork17
 - 4.4.1 Mounting of the metalwork17
 - 4.4.2 Sensor location.....18
 - 4.4.3 Sensor mounting19
 - 4.4.4 Sensor maintenance.....19
- 5 Integration to the vessels navigation system 20**
 - 5.1 System selection on startup.....20
 - 5.2 Connecting to the bridge network.....20
 - 5.2.1 Network.....21
 - 5.2.1.1 DMZ22
 - 5.2.1.2 Uncontrolled or foreign network22
- 6 Setup of users and options..... 23**
 - 6.1 Setup of Users23
 - 6.2 Setup of the system options24
 - 6.2.1 Available Options25
 - 6.2.1.1 Option EML1200.....25
 - 6.2.1.2 Option Reverse25
- 7 Setup screens and configuration of the system 25**
 - 7.1 Set up of the network, serial and other communications (Communication setup)25
 - 7.2 Output formats26
 - 7.3 Accepted inputs27
 - 7.4 Auxilliary outputs28
 - 7.4.1 Speed limits output29
 - 7.5 Setup of the System parameters29
 - 7.6 Alert setup and usage34
- 8 Calibration 36**
 - 8.1 Status37

8.2	Installation angle.....	37
8.2.1	Speed Calibration	38
8.2.1.1	Sea test speed calibration	39
8.3	Temperature offset.....	43
8.4	Auto calibration	43
9	Verifying, Supporting and Maintenance of your system	44
9.1.1	Diagnostic screen	44
9.1.2	Simulate speed.....	44
9.1.3	Software upgrade.....	45
9.1.4	Simulate alarm	45
9.1.5	Self test.....	45
9.1.6	Hardware Reset button.....	46
9.1.7	5 second press.....	46
9.1.8	30 second press.....	47
9.2	Calibration check.....	Error! Bookmark not defined.
9.3	Logging screen	47
9.3.1	The graph	47
9.3.2	Logging options	47
9.3.3	Printing data.....	Error! Bookmark not defined.
9.4	Periodical maintenance of the system.....	49
9.4.1	Display.....	49
9.4.2	Electronics	49
9.4.3	Valves	49
9.4.4	Tanks	49
9.4.5	Mounting.....	49
9.4.6	Sensor/transducer.....	49
10	Runtime displays and setup	49
10.1	Runtime screens.....	49
10.1.1	Top bar	50
10.1.2	Dimming.....	50
10.1.3	User setup	50
10.1.4	Alert panel.....	50
10.1.5	Sidebar	50
10.1.6	Menu.....	50
10.2	The Runtime setup.....	52
11	Retrofitting to an older EML224 system	52
12	Getting started guide.....	53
	Getting started with mounting:	Error! Bookmark not defined.

1 Introduction

The EML1100 / EML1200 is a graphic Speed Through Water (STW) only speed log consisting of a display, an optional electronic buffer/power unit, and a 60mm sensor. The sensor can be mounted in a valve (recommended for easy cleaning and maintenance), or in a tank. A number of retrofit solutions are designed allowing it to replace an older unit from SKIPPER or other manufacturers.

The User interface is Openbridge web based and can be called up on any web terminal within the same network.

The system can be purchased as a 2 axis system (EML1200) or as a lower cost single axis system (EML1100) As the hardware is the same on both, the EML1100 can be upgraded to EML1200 at a later stage using a pay option.

The system follows the speed accuracy regulations of better than 2%, but is typically <1% with a good calibration. Resolution is 1dp by default, but 2dp can be shown as an option. The distance accuracy is the same as the speed accuracy. Resolution if distance is 0.1NM, up to 999999.9 NM

2 EML Principle of operation

The Electromagnetic Speed log is a compact 2 axis speed through water speed log. The system introduces an electromagnetic field into the water just in front of the sensor, and using Flemmings right hand rule, detects a current between electrodes on the front surface of the sensor.

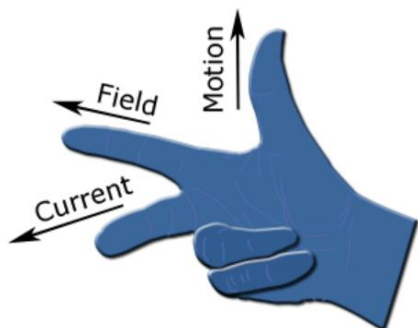

This means the system gives an accurate 2 dimensional measurement of the speed of the vessel through the water at the surface of the sensor/vessel hull. As the hull can drag some water with it, a calibration is needed to adjust for both angular mounting errors of the sensor, and speed differences between the sensor reading and the actual speed through water at different speeds.















3 Terminology

3.1 Units







Parameter	Unit	Abbreviation
Distance	Nautical Miles	nm

Speed	Nautical miles per hour	kn
Pulse speed	Pulses per nautical mil	p/nm
Temperature	Degrees celsius	°C

3.2 Abbreviations

Abreviation	Meaning		
STW	Speed of vessel relative to the water		
SOG	Speed of vessel relative to the Sea bed (Ground)		
Temp	Temperature		
Trip	Daily trip counter (resetable)		
Total	Total distance sailed since installation		
LAN	Local area network		
NMEA	serial communication standard equivalent to IEC61162-1		
Symbol	Meaning	Symbol	Meaning
	User administration		Silence audible alert
	Menu		Additional information
	Alert		Expand
	Dimming		Sub folder
	Edit		Help
	Settings		Standby
	Transversal speed		Longitudinal Speed

3.3 Alert Symbols

Symbol	Status	Sound
	Unrectified, ,Unacknowledged	2 beep repeated after escalation time
	Rectified, Unacknowledged	No beep
	Unrectified, Acknowledged	No beep
	Rectified, acknowledged (Normal)	No beep
	Silenced alert	No beep for 300 seconds
	Responsibility transferred	No beep
	Caution	No beep

4 Physical Installation

4.1 Installation of the screen

Packing list for this system is as follows:

Part number	Description	number of
CU-M001-SA	10.1" Display including plugs for the 4 connectors (mounted)	1
M-Kit-CU-M101	Mounting kit containing: tapping mounting screws mounting bolts cable ties	6 6 6
M-Kit-CU-XBEEP	Buzzer on cable with plug	1
Getting started sheet	A Sheet with QR codes to the latest manuals, and installation guides.	1
Sensor in mounting	EML224SXX-SD where XX = G for gate valve (1,2) T for combo tank (6)	1

	DB for 100mm sea-valve (3,4,5) STA for aluminium tank(7) (number is the valve it fits in) Retrofit versions SN for Simrad NL SNFIII for naviknot III STXM19 for XM-19 tank SV for naviknot SRD331 or 450D SX for SKIPPER PCSV60 valve others may follow	
Optional extras		
Sea valve or tank	One of (if not retrofit): SB-60-SA 60mm sea-valve (recommended) + SB-60-SA-M-KIT DB-60-SA 60mm double bottom sea-valve + DB-60-SA-M-KIT SB-100-SB 100mm sea-valve (Ball-valve) + SB-100-SB-M-KIT DB-100-SB 100mm double bottom sea-valve + DB-100-SB-M-KIT SB-100-SA 100mm Gate-valve ETNSTC Steel tank ETNALC Aluminium Tank	optional
M-KIT-CU-IP56	rear mounting kit for IP56	optional
GC-202-SA	isolator for USB connections	optional
JB40Pow-SA	Electronic buffer unit	optional
Other Options	CD401MR-SB Multi repeater IR301 Speed log repeater IR31DIM-SA Remote NMEA dimmer Moxa managed switch JB12-SA 12 Junction box	optional

The Display is a 10.1” display and can be mounted from the front (IP22) or from behind (IP56). The connections can be fastened using provided cable ties. The screen should be firmly grounded to the ships chassis.

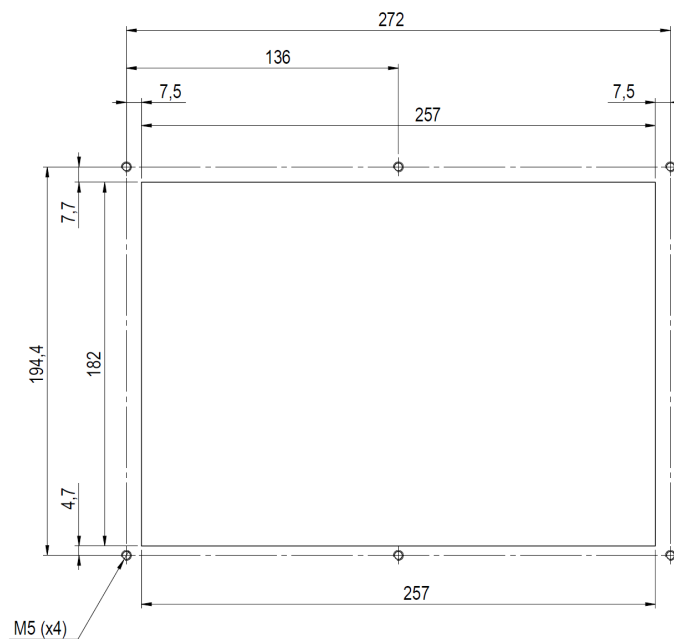
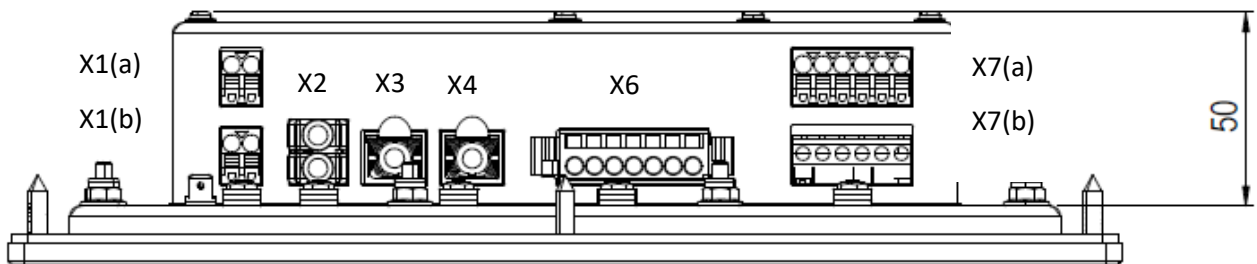
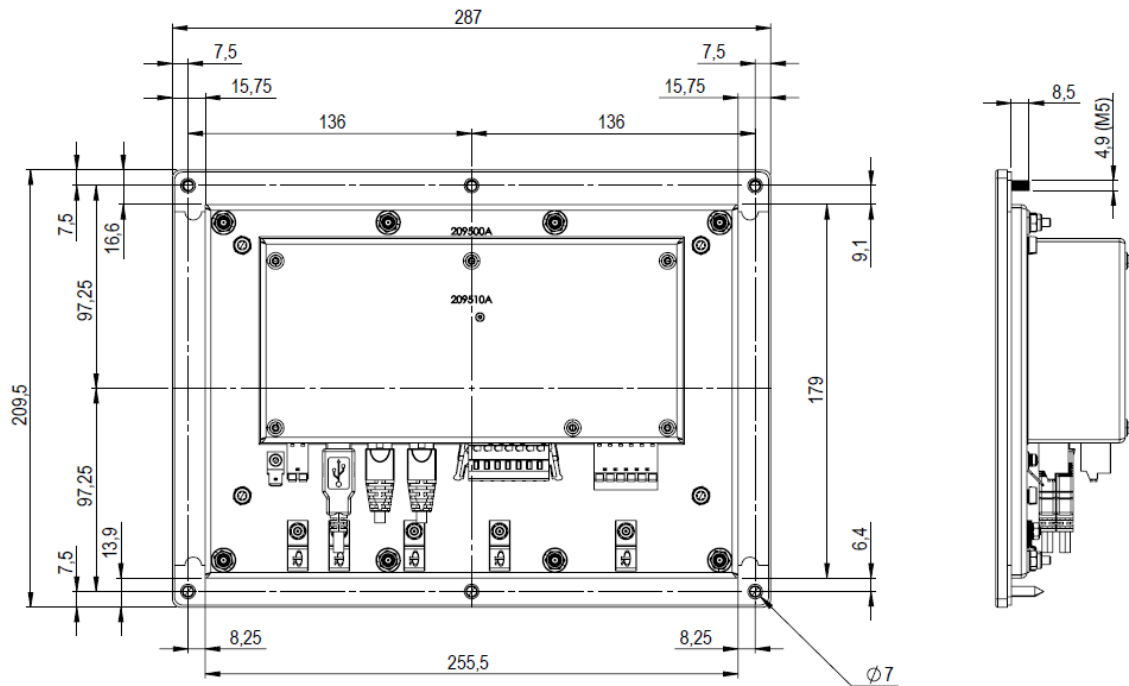

Cutout

For rear mounting, or if IP56 is required, the display should be back mounted using CU-IP56 clips (Art number M-KIT-CU-IP56).

2 sets of screws/Bolts are provided, self-taping for wood for soft surfaces, and bolts (M5) for mounting to metal plate, or with nuts.

If Alerts are to be signalled from this unit, and the unit is flush mounted to a console the supplied external beeper will ensure the high enough volume. If the unit is stand alone, the internal beeper is loud enough on its own.

The provided Beeper (Supplied with the display or part M-KIT-XBEEP), and should be attached to a prepared, clean area on the rear of the console. Make an 8mm hole, clean using solvent based cleaner, and attach using the tape provided.

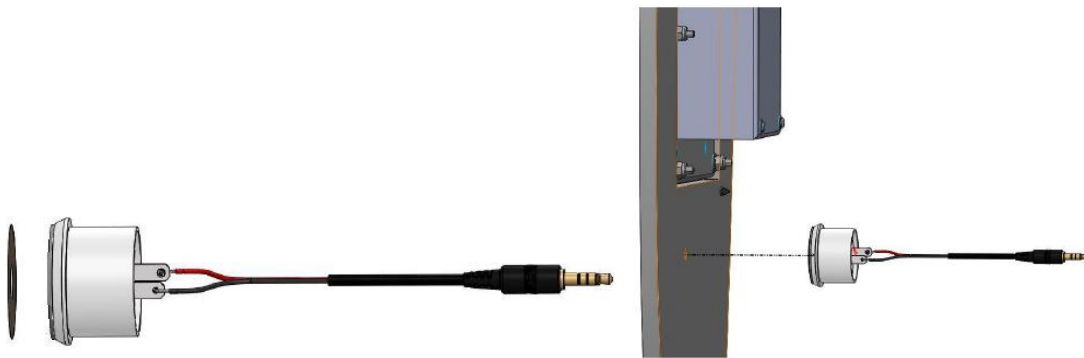

4.2 Connection of the system

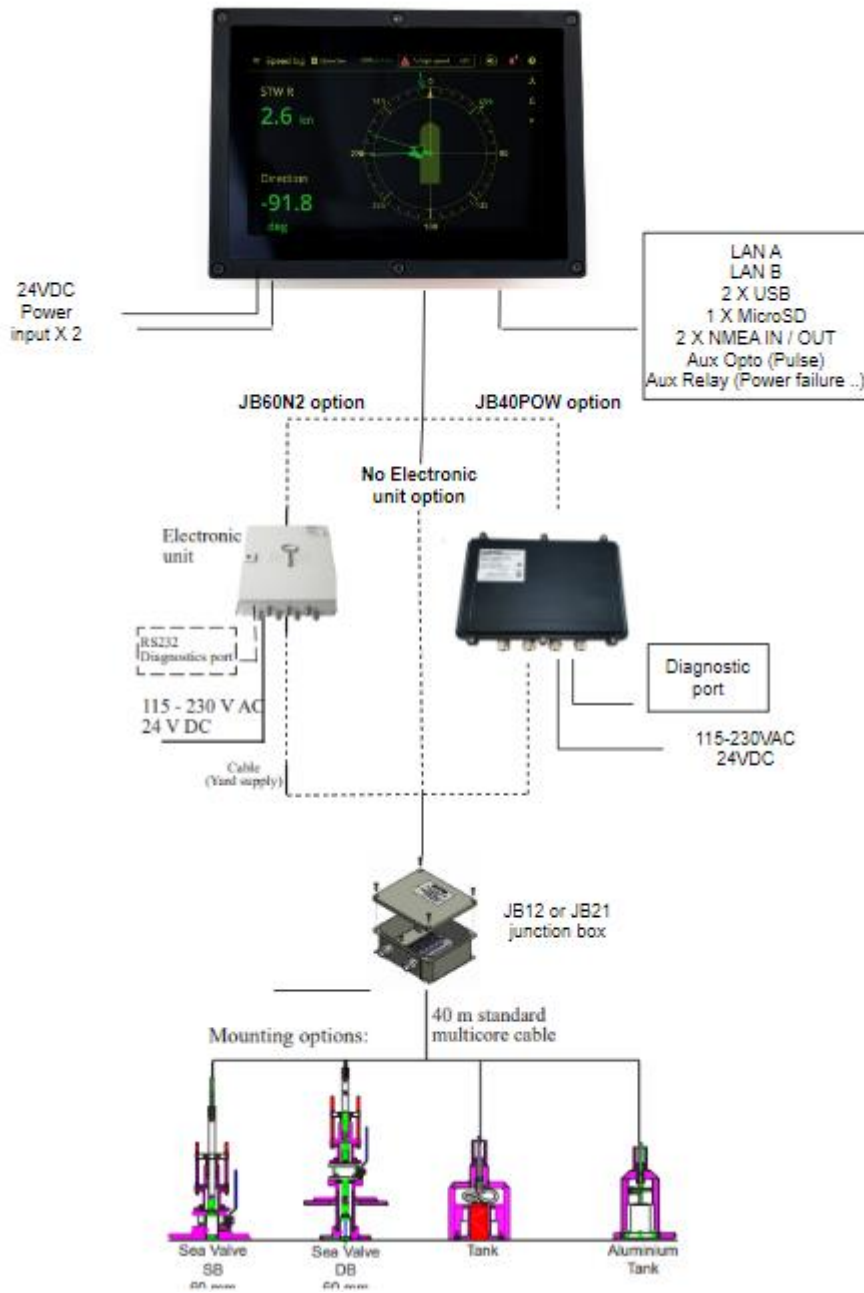

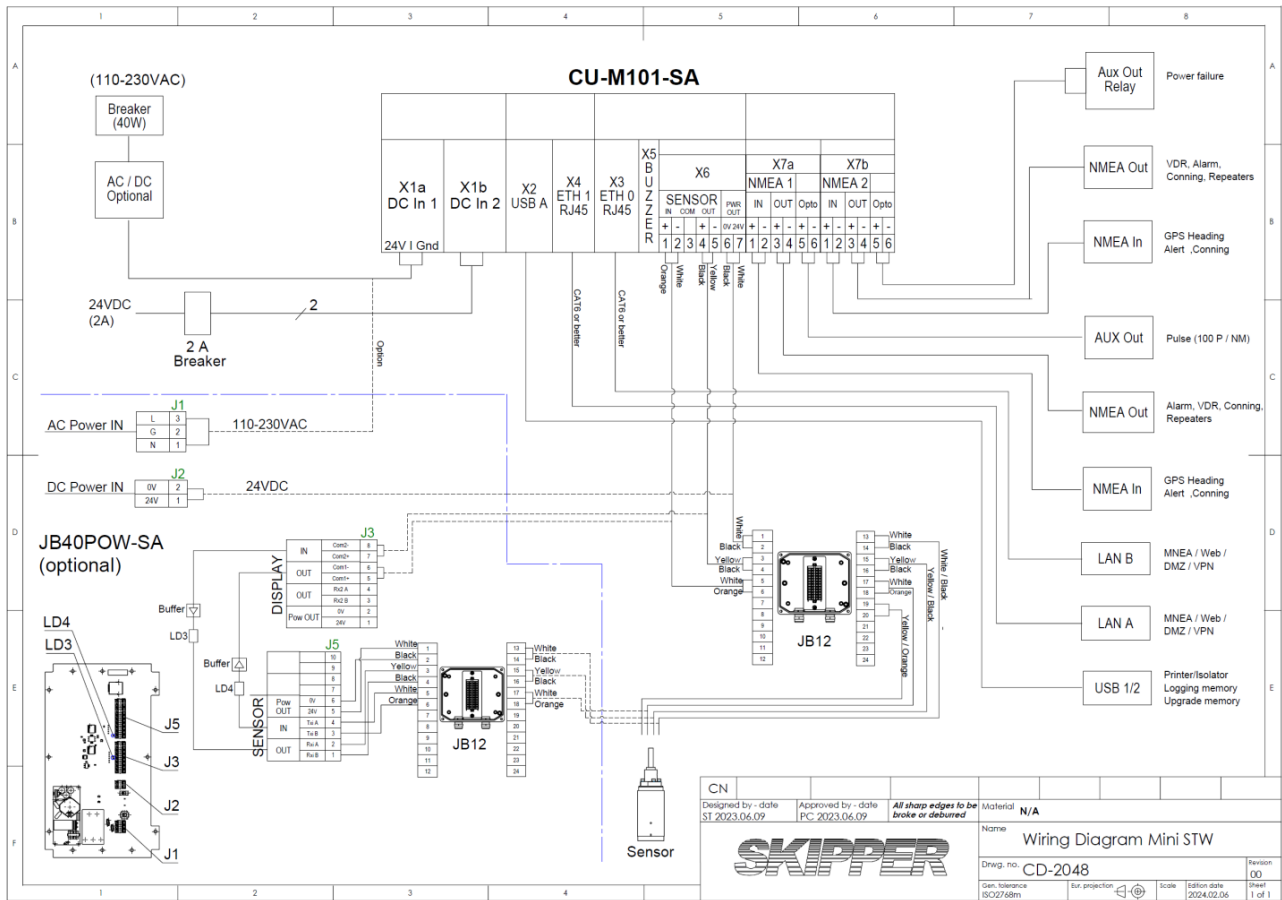
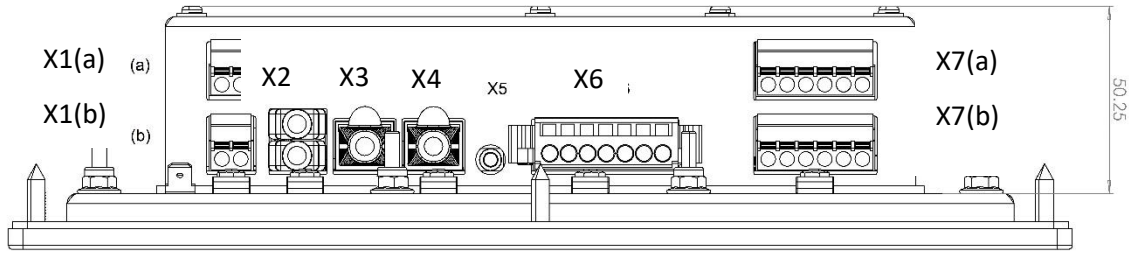







Connection can be direct to the sensor from the sensor port, or via an optional JB40Pow Electronic unit. The JB40Pow unit can be mounted near the sensor or on the bridge and provides a power, buffer and diagnostic ports for the unit.

4.2.1 General Cabling

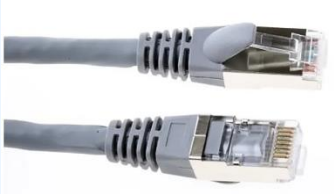
Cables between the system electronics and the rest of the vessel should use standard twisted shielded yard supply cabling, Shield of the cables should generally be connected to the grounding points.

The connectors in use on the Display unit a of type

Connector type	Connector plug	Wire type	manufacturers part nr	picture	provided
X1a , X1b	2 pin spring connector, for power	Screened 0.5-2.5 mm ²	Degson 2EDGKD-5.08-02P-14-00A(H) Part Nbr. 10020000581		2
X2	USB	All USB type A	All accepted, Note: USB memory should not have - voltage connected to chassis, for permanent fixtures use isolator Pnr. GC-202-SA		No
X3, X4	Ethernet RJ45	CAT6 or above, max 100 m	8P8C connector with ANSI/TIA T568A/B pin assignment - All accepted (screened or not screened)		No
X5	External beeper	3.5 mm mono jack with beeper	all accepted, but provided as part of M-KIT-XBEEP		1
X6	7 pin Spring connector for Sensor	0.5- 2.5 mm ² see table below	Wago MCS MIDI Classic 231-307/037-000 Part Nbr. 51117461		1
X7a, X7b	6 pin spring connector for NMEA and Aux	0.5-2.5 mm ²	Degson 2EDGKD-5.08-06P-14-00A(H) (Part Nbr. 10020000585)		

Wires should be terminated with appropriate crimp pins cables size should be 0.2-2.5 mm² (28 to 12 AWG)

4.2.2 Connecting to the Aux outputs

The Display has 2 Aux outputs:

The connector X7a has an opto-isolated output, used for Speed pulses, this requires a voltage on the input of at least 3.3VDC, and this will be switched up and down to provide a speed.

Connector X7b has a normally closed relay, that can be used for Power failure alarm (closed circuit when no power).

Both connectors can be used for other functions defined in the AUX setup screen.

4.2.3 Network cables

Standard network cables can be used from the system using RJ45 connectors. we recommend Cat 6 or better cabling. Network cables should not be greater than 100m in length.

4.2.4 Cabling to the sensor

The sensor is supplied with 40 m of cable. This should be guided to a dry area where a junction box (yard supply or SKIPPER part JB12) should be used to extend the cable to the bridge. The sensor is a smart sensor and outputs propriety NMEA messages. This standard is based on RS-422, so cable lengths should not be a problem. **The cable can be cut or extended.** However, power is sent down the cable and the sensor should have at least 16 V at the sensor junction box to function normally. If the voltage is low, we recommend using the JB40POW unit as a buffer for both signals. The JB40 has both AC and 24VDC power, and AC will travel over longer distances than DC so can be used to provide power from the bridge.

4.2.4.1 Cable Dimensions

Cable length	Cable type	Alternative
Up to 40m	Use supplied cable	
Up to 100m	4 Twisted pairs min 0.5 mm ²	
Up to 200m	4 twisted pair min 0.8 mm ²	
Up to 400m	4 twisted pair min 1.5 mm ²	use 0.8mm ² with JB40Pow in middle with AC power cable.
Up to 600m	Use 1.5 mm ² and JB40Pow with AC.	

Although the signals on the cable are digital, it is recommended to avoid electrically noisy areas such as pneumatics and generators.

4.2.5 Optional JB40 unit

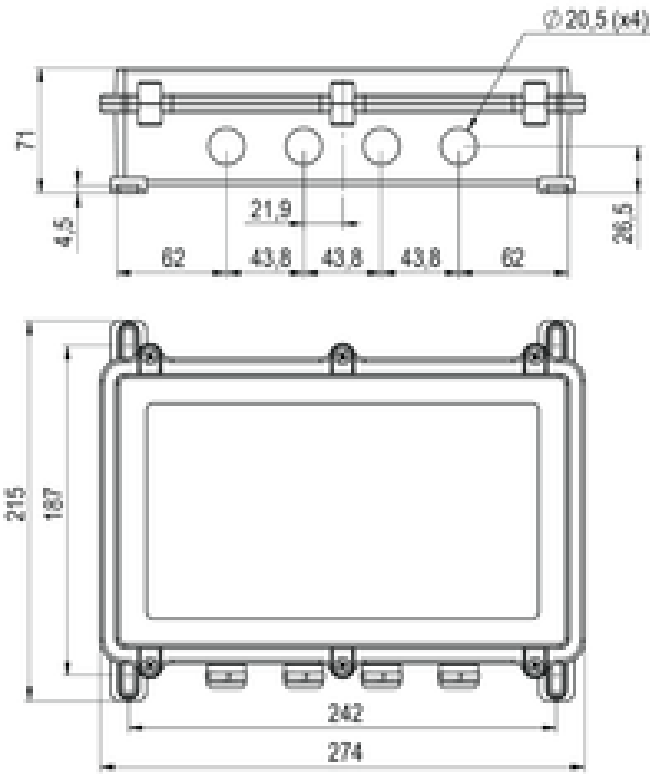

4.3 Power requirements:

The Display unit and sensor can be powered by 24V from the display, The JB40Pow unit can be used as a AC DC converter, so that the display is connected powered from the JB40POW, alternatively the JB40Pow can be powered from the display. Normally the power to the whole system should be from a circuit breaker near the bridge (2A rating or 50W rating). The system provides two 24VDC inputs, to allow redundant power, these are monitored for poor voltage, or power failure. If only one Power input is used (Usually requiring a UPS instead) Then the unused power input can be deselected in the system setup menu, to prevent unnecessary alerts.

4.4 Installation of the sensor and metalwork

4.4.1 Mounting of the metalwork

This must happen in dock and care should be taken to mount the valve/tank such that the sensor will be flush with nothing to cause turbulence near the sensor. The sensor should be mounted forward in the vessel, preferably just behind the bulb.



Important! Tank mountings have an orientation (an arrow, slit that must point forward).

The sensor is fully water-tight and can be mounted in wet areas such as ballast tanks. Please see the separate mounting user guide for more details.

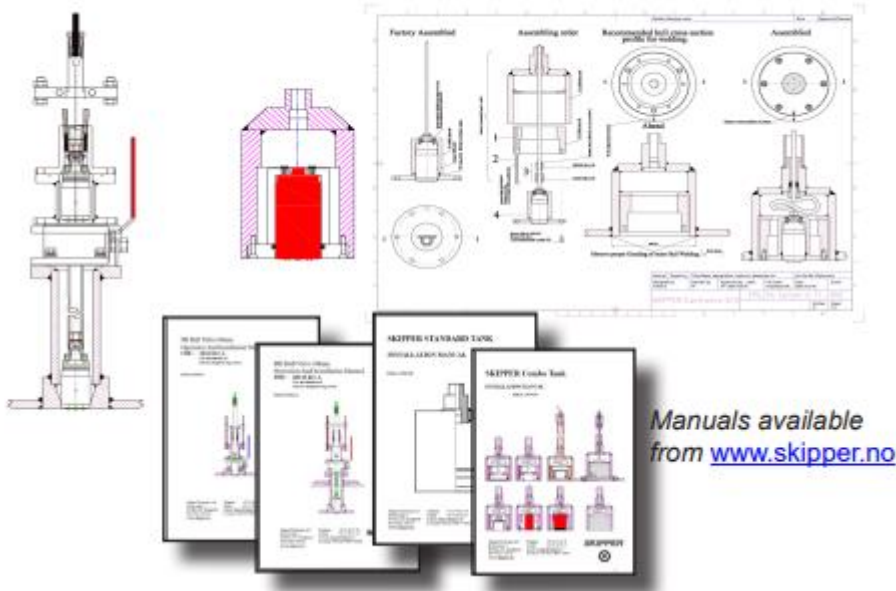

4.4.2 Sensor location.

For proper operation, the sensor should be installed close to the bulb or the bow of the ship, avoiding areas where it may be damaged by the anchor chain. It is, of course, necessary to select a part of the hull that is submerged under all load and speed conditions.

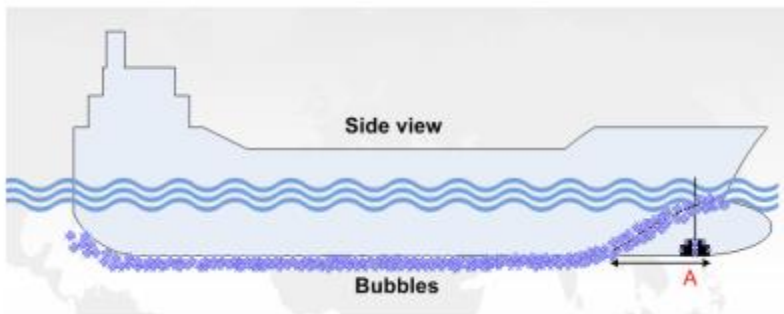

For 2 axis speed logs the transducer should be positioned as deep as possible on the hull. The transmitting surface of the transducer must be installed horizontally.

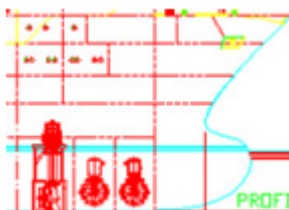

A typical recommended area for installation is fore part of the bow thruster room. The sea valve with sensor can be installed in a ballast tank, but it is not recommended. It is necessary to position the sensor on a hull section which will ensure a laminar water flow for all angles of measurement. If such a flat section is

not available, the shipyard must construct a suitable bed. If the vessel is designed with a box keel, this can be used for installation of the sensor. In this case, adaptable length hull fitting (double bottom valves), and sensor may be ordered from SKIPPER. Before the hull fitting installation procedure is initiated, always check that the hull fitting valve can be properly operated and that the sensor can be removed in the selected location. See installation manual for the valve solution for more information.

4.4.3 Sensor mounting

Please see the installation manual for the valve. Installation may differ between the different valve solutions available.

The sensor can be mounted and powered in air and water. Briskly rubbing the face of the sensor will show changes in values in the speed. It is very important that the sensor is mounted in the correct orientation, (especially single axis units). In a tank, the arrows should point forward. On a ball valve, the flat area of the extension tube should point on the port side.



Tip: Placing a large flat straight pole on the flat area will allow accurate adjustment. Alternatively a laser level can be used to get accurate orientation on a remote bulkhead.

Small errors in angle can be calibrated, but care should be taken to get this as accurate as possible. Each time the sensor is lifted or repositioned, the angular offset should be checked.

4.4.4 Sensor maintenance

The EML sensor requires regular cleaning as growth on the front of the sensor will show slower speeds. The calibration can be adjusted to compensate.

The plastic of the sensors can be damaged if they are scraped with a hard object, we therefore advise to remove large objects and then use a hard plastic scraper to remove as much of the remaining growth as possible. You must not use sandblasting or high-pressure cleaning tools on the sensors/transducers.

The metal of EML pins should be visible and in contact with the water after cleaning. We do not advise using antifouling coatings on the sensor itself, but in the surroundings can help.

Maintenance period for an EML can vary from 6 months upwards, depending on how movement of the vessel and the water temperature.



Important! Speed log sensors have an orientation. (an arrow or dot on the front of the sensor)



Important! Do not paint or coat the front of the sensor

5 Integration to the vessels navigation system

The EML1100/1200 are designed to simply integrate in the modern bridge. The unit supplies two networks, two NMEA input and output, an Aux-pulse and Aux-relay output. In addition, two USB's can be used for connection to memory stick or printers. USB and SD disks are tightly controlled and will only be activated if the user requests a valid operation to be performed. Only data encrypted by SKIPPER tools will be accepted. There are no plug and play options available.

All settings on the system are password controlled with 4 levels of security.

No user: view only

User: Control operational functions (alert limits, alerts, trip reset and user screen setup)

Service: Change Settings

Admin: As service but with User configuration control.

All levels above user will default to user after 4 hours with no interaction. The user level passwords can be reused, even through a reboot, if the keep password option is checked on login.

5.1 System selection on startup

The EML1200 can be supplied fully setup, or the system type can be selected on site using a code number. If the system has not been setup in the factory, a setup screen will show on startup, password is the serial number. Here you must enter the supplied code for the system and then the system will setup. If this code is not available it can be downloaded from SKIPPER website or by using the QR code that shows on the screen.

5.2 Connecting to the bridge network

The System is built up to meet many of the current and future cybersecurity standards, although the obligatory standard is IEC-61162-450 and IEC61162-460. The system is set up with a secure area and public area. The vessels network only has access to the systems public area. All data not following the IEC61162-450 standard will be encrypted. Upgrade of the system is still expected to be performed by use of USB or a locally connected PC. If the defined connected systems are changed (detected by MAC address), the system will give a warning and the user must approve the use of the new connection.

Files structures and security levels

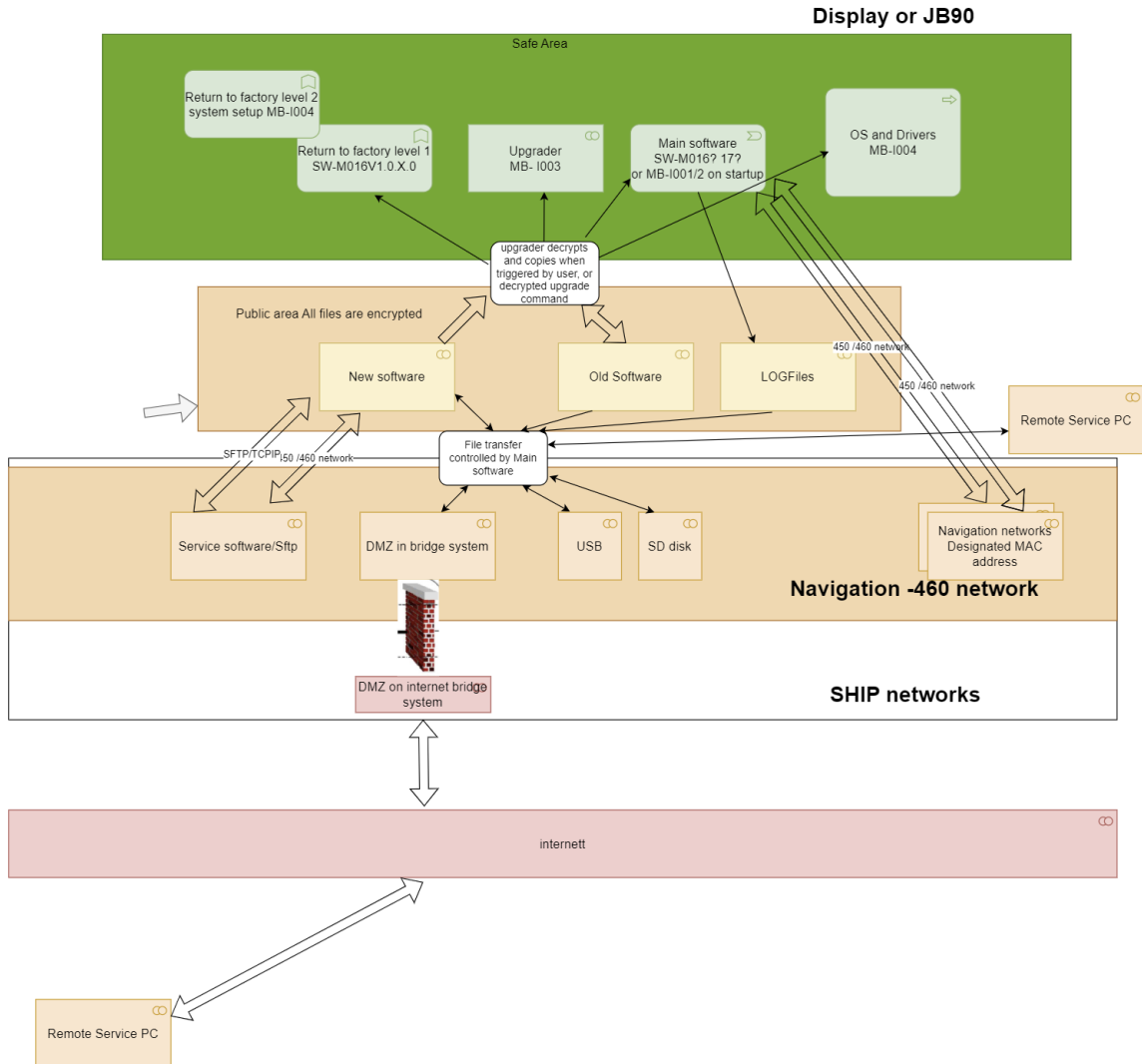

5.2.1 Network

The system has 2 independent network ports, both communicate with both TCP/IP and multicast (UDP) (IEC61162-450) this allows the system to be connected to the ships internal networks. Connection is recommended via a Managed switch, which is programmed to reduce the unnecessary traffic between other systems. This switch should normally be registered as the approved network. The Moxa EDS-408A is tested with the system, but other suitable approved managed switches may be used. Information on setup of the Moxa switch is available on their website www.moxa.com

A Software switch option is available in the communications setup pages to connect ETH1 as an extension of ETH0. This function is only available at Admin level for cybersecurity reasons.

This port can provide communication both by TCP/IP V4.0 and using IEC61162-450 V1 and V2, and IGMP V1 to 3. If being used it requires a network that does not exceed 80kbits/second directed to the system. The system will exert/receive a maximum load of 45 datagrams/second. The network load should not exceed 300Mb/s. The LAN ports on this system support IEC61162-450 V1, and V2 and IGMP V1 to 3.

IP Address: The IP addresses can be assigned in the communication setup pages, but are by default 172.16.1.50, and 172.16.2.51. ETH0 and ETH1 must be in separate domains unless internally connected

together with the option in LAN tab in the communications setup. If the LAN ports are connected, both will use the LAN settings for ETH0.

SFI (System Function ID): Each device has its own identifier (SFI) and the systems can then identify who they are and who they are talking to. These should be unique within a vessel and will start with an identifier of VM. Default is VM0112, Not having unique values, may cause errors on systems trying to communicate with the system, such as alert management or INS.

The system contains a log of errors following the IEC61162-450 standard. This can be accessed by sending the following command to the system `PSKPVMPGCTERR,9*nn` This will return error numbers 70-84 with the number of occurrences

```
$PSKPERORTABLE,70,71,72,73,74,75,76,77,0,0,0,0,0,0,0*1E
```

where the following 0, indicate the number of occurrences

```
$PSKPERORTABLE,78,79,80,81,82,83,84,0,0,0,0,0,0*23
```

Error number	Error type	Error number	Error type
70	Too long UDP message or checksum error	78	Total rejected messages
71	Error missing tag or tag checksum	79	Header (Wrong UdpBc)
72	Error in tag format (only s:,n:,d:,g:, tag not =0000, n=4 digits)	80	Image Block size error
73	Tag framing errors /missing or empty tag, ,, or too long tag (>80)	81	Missing Datagram
74	incorrect NMEA length (overflow)	82	Invalid Header (RaUdp)
75	UDP datagram length (overflow)	83	Udp Overflow (>1460 Byte)
76	Error in msg format; no \$ or !, no CRLF, ID not 5 characters (except \$P)	84	Total Rejected
77	Bad sensor data (too low quality)		

5.2.1.1 DMZ

DMZ operations are not implemented in the current version - The Ships DMZ is intended to be used for transfer of data and software upgrades. Contact Jotron SKIPPER for more details.

5.2.1.2 Uncontrolled or foreign network

The standards (IEC61162-460 § 6.3.4) require that If an uncontrolled network is connected the system will block it, unless the user allows the connection.

On connection of a new device to one of the LAN ports, the system will block this and give a popup warning on screen with 3 options:

- Block – The connected device will not be given access.
- Allow – The connected device will be connected but a system caution with title ‘uncontrolled device connected’ will occur and be escalated to warning after 5 minutes.
- Approve – The connected device is the permanent device for this port (i.e. a managed switch). No alerts will be sent when this device is detected.

The Approved network, will usually be the MAC address of the connected managed switch, but can also be a central, permanent part of the network.

If the approved network key point is to be changed, the network can be selected within the LAN settings in communication menu

, and the Approved network MAC selected. On pressing this the popup menu will again be presented with all the detected MAC addresses within the network.

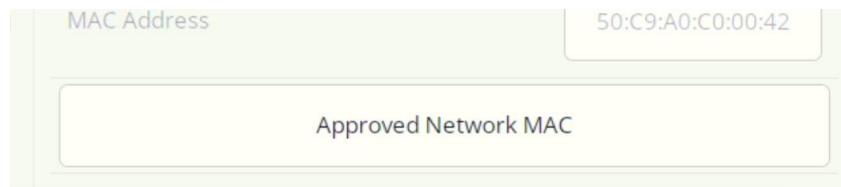

Important! Any PC in use within the ships network or directly to the system should be secure to the vessels or service companies standards

6 Setup of users and options

6.1 Setup of Users

The system is supplied with 3 users ‘admin’ , ‘service’ and ‘user’ , each with a password of the system serial number with no forwarding 0’s. These should be changed.

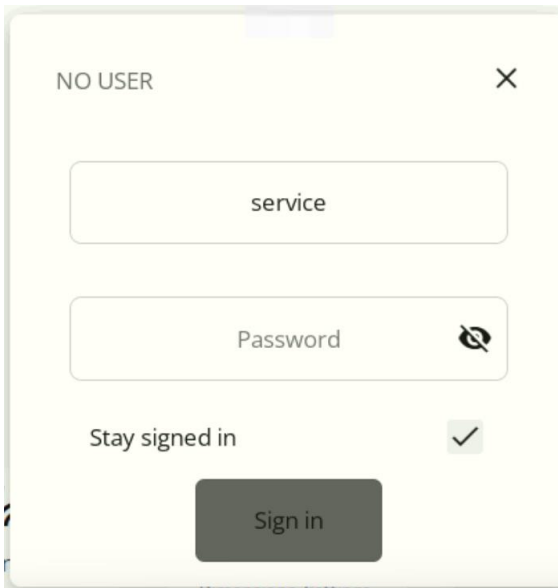

Passwords should not contain the user name or parts of the user's full name, such as his first name, company name, product name, etc, dictionary words should not be used, repetitive or sequential characters (e.g. 'aaaaaa', '1234abcd') should not be used, random and meaningless passwords should be used.

Passwords must be minimum 8 characters and contain a number or character, upper and lower case

The default is NoUser, and clicking on the user icon will allow a password and username to be entered / changed.

By default, the User needs after a reboot, or logout. Clicking on the 'Stay signed in' Checkbox, will keep the current user logged in after a reboot. User level login will remain logged in for up to a year, however higher login features as shown in Service (setup) and Admin user (user management) will be deactivated after a period of 4 hours, at this stage a popup will remind the user to log in again. The user will only be able to perform user level activities without re-entering the password.

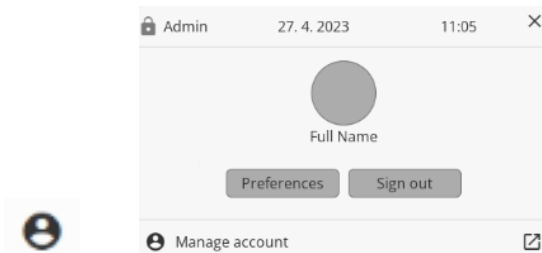

The Admin user on entering manage account option will be allowed to administrate users and add options. Other user levels are able to change their passwords.

6.2 Setup of the system options

System options are selected from the Admin manage account page. Adding the correct code within the password/code field will enable or disable the options. On enabling, the features of these options will become available within the setup screens and can be individually activated or disabled. If the display is replaced, the option codes will change as they are based on the system serial number.

6.2.1 Available Options

6.2.1.1 Option EML1200

If the system is setup to EML1100 (single axis) then using a pay code, the second axis can be activated. Part number AC-EML1200-UPG

6.2.1.2 Option Reverse

If selected, the system is installed on a vessel that can sail at full speed in both directions. This switch turns the bow and stern, and rotates the Axis of the system, it is triggered by NMEA message 'EPV', (or AUX input if available).

The command to reverse the vessels direction (when the option is activated) is:

\$--EPV,C,VM,121,50,Y*nn for rotated direction and \$--EPV,C,VM,121,50,N*nn for Normal direction, Where 121 is the SFI number of the system, the system will reply with a copy of the command with R instead of C.

7 Setup screens and configuration of the system

Setup screens are activated by entering the menu (using the hamburger symbol top left), and selecting the button for the required setup. The search can be used to go to the exact button you require if you know its name. Pressing on the icon in the top left, will allow you to go to the setup levels above the current display. The 'x' button will return to the runtime screens.

7.1 Set up of the network, serial and other communications (Communication setup)

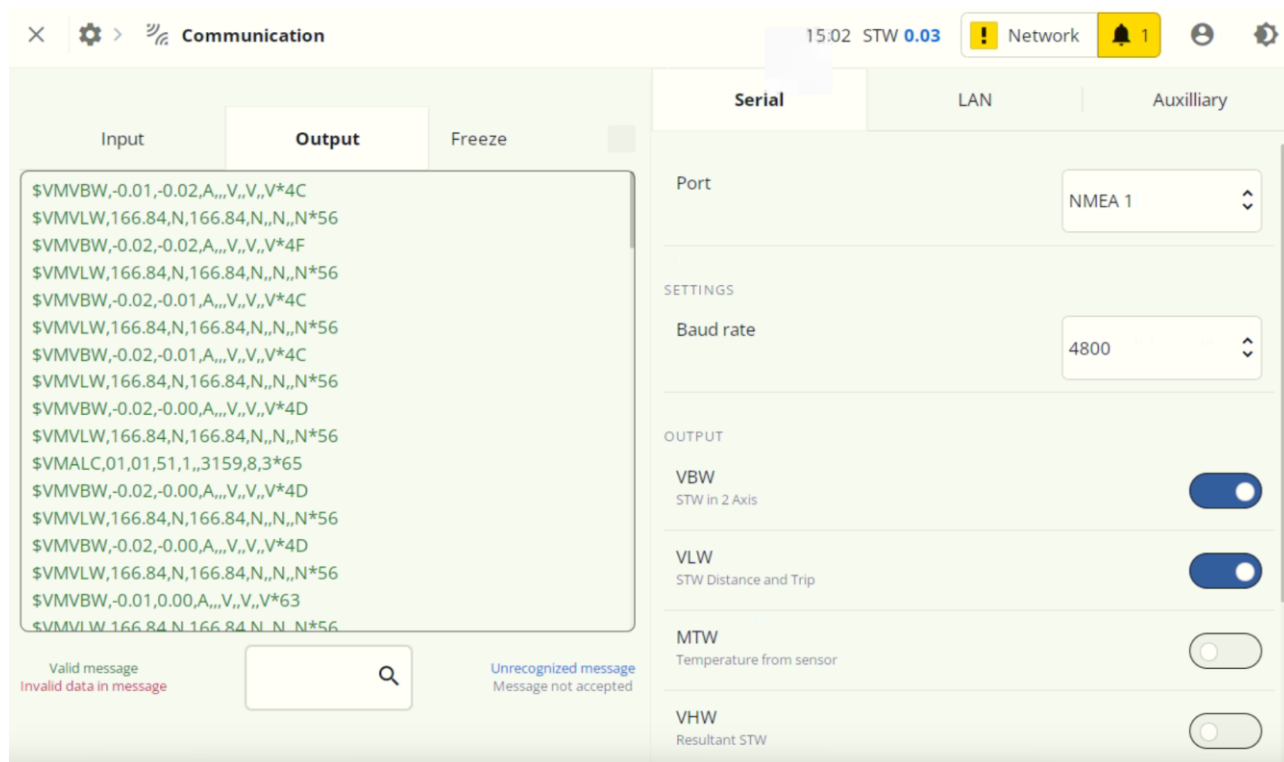

The screenshot displays the 'Communication' setup screen. On the left, there is a list of NMEA messages under the 'Input' tab, including commands like \$VMVBW, \$VMVLW, \$VMALC, and \$VMVW. Below this list is a search bar and a legend for message validation. On the right, the 'Serial' configuration panel is active, showing the 'Port' set to 'NMEA 1' and 'Baud rate' set to '4800'. Below these settings are four output options, each with a toggle switch: 'VBW' (STW in 2 Axis), 'VLW' (STW Distance and Trip), 'MTW' (Temperature from sensor), and 'VHW' (Resultant STW).

The left side of the display shows a terminal emulator of the information arriving or leaving the system. The user can change from output to input, freeze the screen or filter for a particular message. The colour code of the messages will show their validity.

The Right side has 3 tabs, one for each Communication form.

Serial allows you to choose the Port number, the baud rate (same baud rate for input and output) and select the sentences to be sent. The standard communications the NMEA outputs are 4800 baud, 8 data bits, 1 stop bit. The system sends 1 message per second (1Hz)

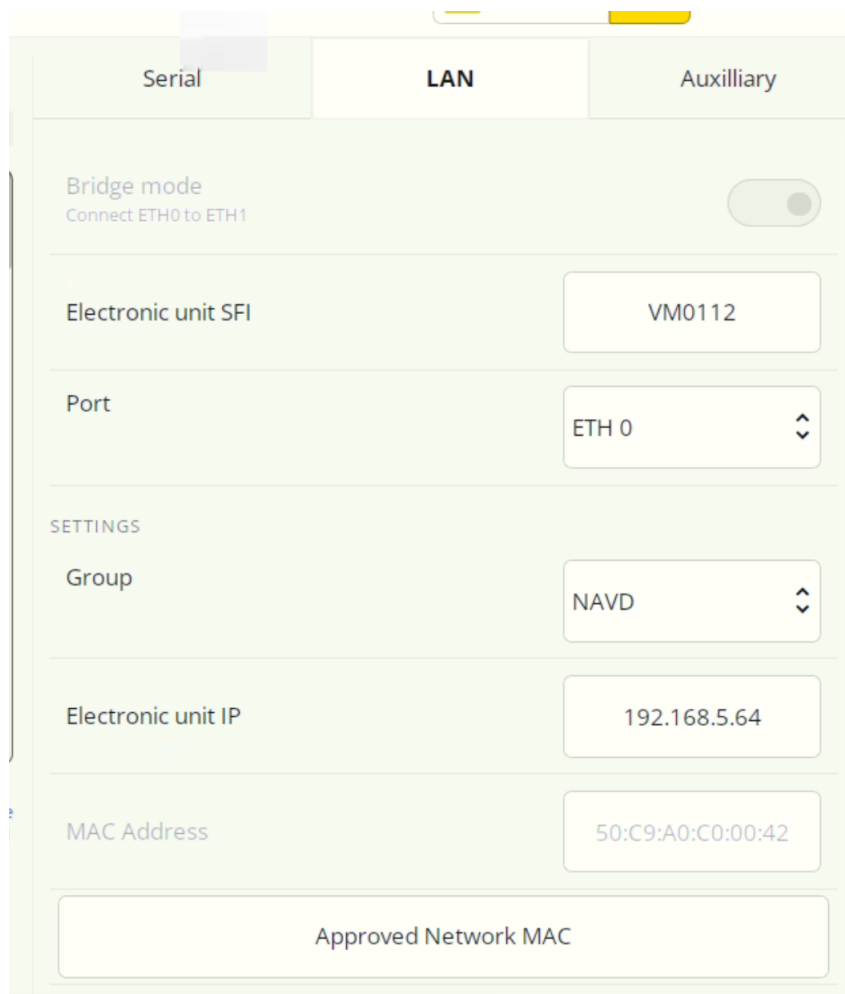

The LAN settings allow System function ID (SFI) to be set (the same on both LAN ports), the transmission Group and the IP may also be adjusted. The 2 IP addresses cannot be within the same subnets. Defaults are 172.16.1.50 and 172.16.2.51.

The two ethernet ports should not be in the same subnet (172.16.subnet.xxx) as this will cause looping internally, even if on different cabled nets.

If the user is using only 1 network, then the 2 connectors can be connected so that they share the same IP and settings as ETH0.

7.2 Output formats

All serial outputs can transmit the following IEC61162-1 (NMEA 0183) outputs:

Sentence	contents	Format example and explanation
VBW	Dual speed forward and aft ID VM indicates at sensor Id 'I' indicates calculated at bow or CCRP (see option in Runtime screens - General	\$VMVBW,X,Y,A/V,,,V,Z,A/V,,V*nn X is Longitudinal water speed Y is Forward Transversal water speed Z is Aft Transversal water speed (if Heading/ROT is available \$VMVBW,10.1,0.5,A,,,V,,V,C*58
VLW	Water Trip and total	\$VMVLW,Trip,N,Total.N,,N,,N*nn Trip - Daily trip through water - resettable on menu Total - Total distance run through water - non resettable N indicates Unit Nautical Miles \$VMVLW,1208.9,N,1210.N,,N,,N*56
MTW	Water temperature	\$MMTW,XX.X,C*nn XX.X is the temperature C indicates °Celsius \$MMTW,13.8.C*02
VHW	Resultant water speed	\$VMVHW,,T,,M,XX.X,N,YY.Y,K*nn XX.X Speed in Knots YY.Y Speed in km/h \$VMVHW,,T,,M,10.8,N,20.0,K*45
Alarm	Alert outputs (ALF, ARC,ALC)	
DDC output	Dimming output	
Combined VBW	Show the Data from the defined sensor position. Make a single combined output using this sensor and external SOG sensor	\$IIVBW,X,Y,A/V,D,E,V,Z,A/V,F,V*n As normal VBW,but a received VBW, for an external Ground speed log (information D,E,F) will be inserted. In this way a combined message can be sent.
Combined VLW		\$VMVLW,Trip,N,Total.N,Ground trip,N,Ground Total,N*nn A received VLW message containing ground trip and total will be included.

7.3 Accepted inputs

The following inputs are accepted by the system, other formats will be ignored or rejected

Sentence	contents	Format
VBW	SOG part of this sentence	
CAN	Alarm acknowledge	
ZDA	Clock date and offset	

	(Recommended)	
GLL	Position and time	
RMC	Position speed and time	
GGA	Position and time	
VTG	Speed SOG/COG	
XDR	Direction (For reverse)	
MWD	Wind direction	
MWT	Wind true	
MWV	Wind velocity	

7.4 Auxilliary outputs

The system has two auxiliary outputs

Aux 1 on connector X7A is an opto-isolated output that can be set to Pulse speed output, Power failure or Speed limit output.

Aux 2 is a relay output that is limited in use to Power failure or Speed limit.

The speed limit allows the user to indicate as the vessel passes through a speed. This is commonly used for stabilisers or rudder limiters.

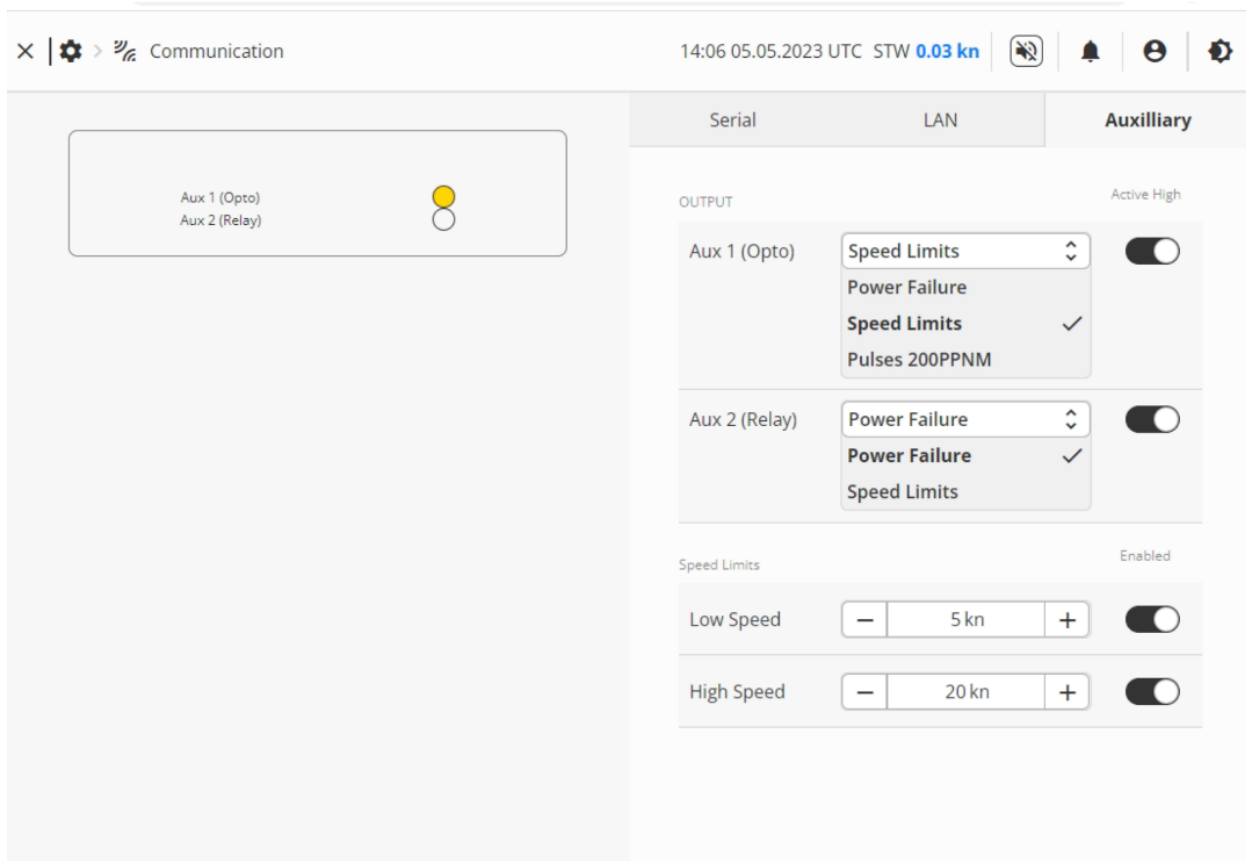

7.4.1 Speed limits output

The speed limit output allows the system to indicate by TTL level when the vessel rises above, or falls below a set speed. There is a high and low, allowing a speed zone to be set, these can also be enabled/disabled if only one speed needs detecting. Although similar to the speed alerts, this function does not generate an alert, and is typically used for stabilisers, waste systems or indications to the machine room.

7.5 Setup of the System parameters

The system requires some information about the vessel it is mounted on. This menu allows you to adjust the following:

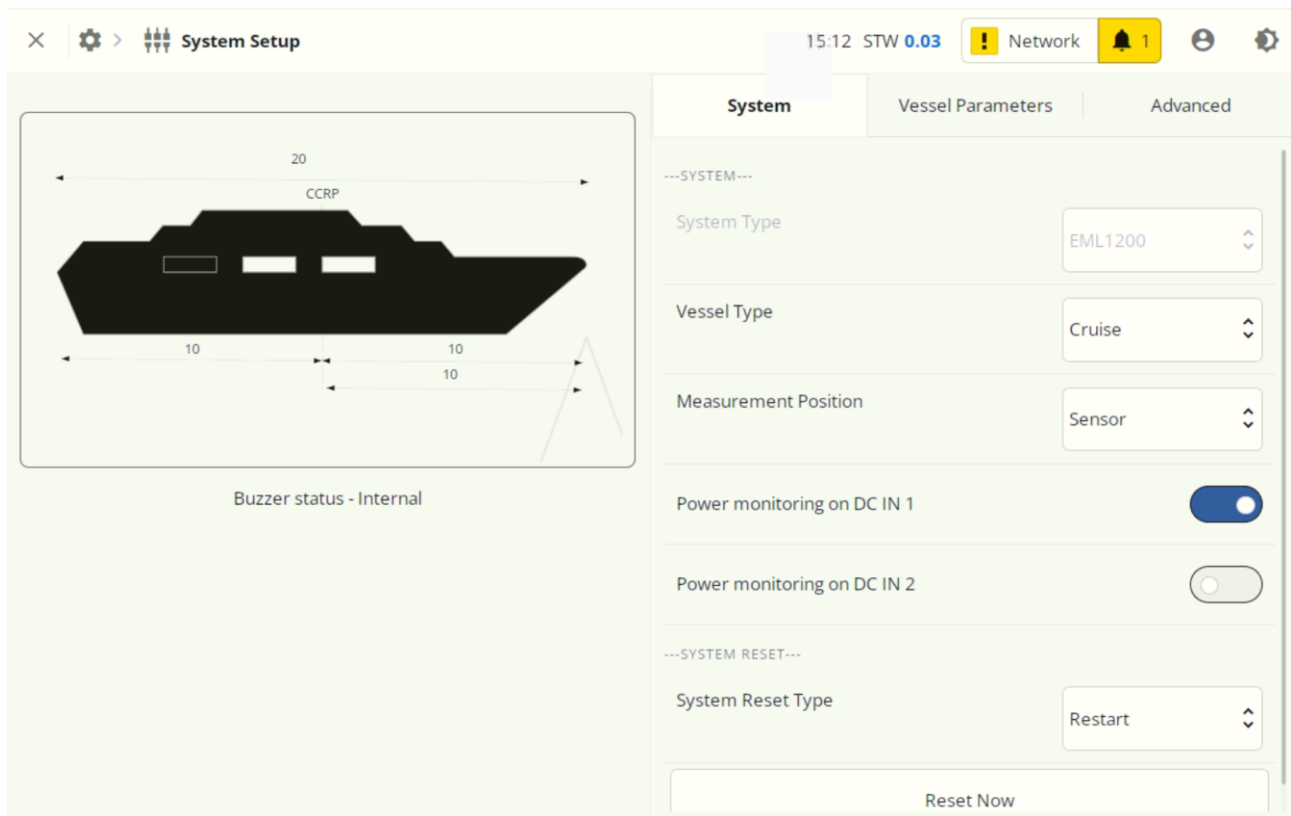

The vessel on the left shows the vessel and the mounting position of the sensor, also the selected buzzer configuration.

Tab – System	Function	Extra information
System Type	EML	Showing the type of sensors in use.
Vessel Type	Image	Show the image of the system
Power monitoring 1	For alerts and diagnostics	This selects which DC input is connected and monitored a poor voltage or lack of voltage on the selected inputs can create a power warning if selected in alert settings
Power monitoring 2	For alerts and diagnostics	As above
System reset dropdown		a selection of the type of reset to be performed. Once selected Reset now button triggers the reset. A hardware reset feature is also available (in diagnostics section)
Reset Now	Perform the reset now.	Various reset levels can be selected, reboot, reset to factory, reset except for calibration and communication settings

System	Vessel Parameters	Advanced
---VESSEL PARAMETERS---		
Max Speed (kn)	<input type="button" value="-"/> <input type="text" value="13 kn"/> <input type="button" value="+"/>	
Sensor to CCRP (m)	<input type="text" value="10.0"/>	
Bow to CCRP (m)	<input type="text" value="10.0"/>	
Stern to CCRP (m)	<input type="text" value="10.0"/>	
Vessel Tonnage (GRT)	<input type="text" value="100.0"/>	
---REGISTRATION---		
Vessel Identifier <small>IMO (required), New Build or Vessel name</small>	<input type="text" value="IMO*****"/>	
Sensor Mounting <small>Enter the sensor type, and the tank/valve Serial number.</small>	<input type="text" value="EML224SS-Tank"/> <input type="button" value="v"/>	
Bottom mounting serial number <small>The number stamped into the valve or tank</small>	<input type="text" value="234"/>	
Disable installation popups <small>If IMO not used as identifier, this turns off reminders</small>	<input type="checkbox"/>	

Tab - Vessel parameters	Function	Extra information
Max Speed	The Max speed to be displayed on graphical elements	Used to show the correct max speed on the speedometer and calibration tables
Sensor to CCRP	Distance from the sensor to steering position	Used to allow the system to calculate the sideways speed at the exact bow of the ship, the CCRP or sensor. as selected in Runtime setup (Relies on heading input) as selected in Runtime setup

Bow to CCRP	Position of steering position relative to the Bow	As above
Stern to CCRP	Position of steering position relative to the Bow	As above
Vessel tonnage	Deadweight of the vessel	Used for filter adjustment
Sensor Mounting	Sensor Mounting type	Used to allow simpler service or sensor replacement at a later stage.
Bottom Mounting Serial no.	Serial number of mounted tank or valve	This information is sent to SKIPPER during registration to allow the correct certificates to be uploaded to the Jotron web interface. This information is stamped on the tank or valve, and the certificates are normally required for vessel approval.
IMO Number	Registration of the vessels identity	Enter the vessels IMO number, or Build number. If a valid IMO 7 or 8 digit number is not entered then a popup reminder will appear on system startup, unless disabled by the toggle switch. This information is registered at Jotron, for efficient service in future
Disable popup	Disable the IMO and SN reminder popup	If the vessel is not IMO registered, then this will disable the reminders. In this case enter the name or identifier of the vessel.

System
Vessel Parameters
Advanced

---ADVANCED---

Filter Type Normal ^
v

Reverse
for 2 direction ferries

Activate option 2dp
option to use 2 decimal places

Buzzer Option Internal ^
v

Diagonal Size - 10.1in +

---OPTION CODES---

Option Code

Activate EML1200 (paid)
To activate EML1200 paid

Tab - Advanced	Function	Extra information
Filter type	Filters used for smoothing of data	
Reverse	When active use NMEA message to flip the bow and stern.	See 6.2.1.2 reverse option
Activate 2dp	When available the switch in	The default speed data shows to 1 decimal place, activating this will show two, both on screen and in NMEA outputs.
Buzzer option	Disable the internal buzzer	Requires an option code, can be disabled if an external BAM system is in use
Buzzer status	None, Internal, External, Both	Giving different sound levels (requirement is 75 to 85 dBA) which is correct if the external buzzer is used.

Option codes	Option codes can be added here to activate paid options	Option codes are sent with the system or can be retrieved from the Jotron SKIPPER web portal, or from service.skipper@jotron.com
Option EML1200	Activate/deactivate feature	If a EML1100 is installed, the Transversal (2 nd) Axis can be activated here.

7.6 Alert setup and usage

The screenshot shows the 'Alerts' configuration page in a web browser. The browser address bar shows '192.168.5.64:7080/settings/alerts'. The page title is 'Alerts' and the status bar shows '04:50 STW 0.06' and a 'Network' alert with 1 notification.

Alert History

Alert Level	Alert Type	Date/Time	Ack	End
!	Network	27.05.2024 01:38:02 (SYS)		
!	Network	27.05.2024 01:37:32 (SYS)		
!	Network	27.05.2024 01:37:32 (SYS)		
✓	Network	26.05.2024 22:22:05 (SYS)		26.05.2024 22:22:05 (SYS)
!	Network	26.05.2024 22:04:47 (SYS)		
✓	Network	26.05.2024 21:53:19 (SYS)		26.05.2024 21:53:19 (SYS)
!	Network	26.05.2024 21:53:01 (SYS)		

ALERT VALUES

- Low Speed: 0 kn
- High Speed: 50 kn

SETTINGS

- Alert Group ETH0: SYSTEM
- Alert Group ETH1: SYSTEM
- BAM/CAM SFI: CA1235
- Escalation time: 2min

ALERTS (CAUTION C, WARNING W, ESCALATION E)

- Low Speed: OFF
- High Speed: OFF
- System Error: OFF
- Internal Error*: OFF
- Power Failure: OFF
- Power Reduction: OFF
- Unsynchronised Clock: OFF

The Alert screen shows on the left a history of the alert situations for the last 500 entries

On the right the alerts to be indicated can be configured.

The speed-log system has 2 function alerts, speed hi and speed low. These can be set to a particular speed and as the vessel passes this speed the alert will sound. The level of these alerts can be set. And the values can be set here or on the main menu setting. and can be shown on the run screen information.

This system does not support aggregation.

Function	Options	description	Text	secondary text
Low speed	Value in 0.5kn steps	Send alert when speed sinks below the set limit	SPEED LOW	SPEED < XX KN
High speed	Value in 0.5kn steps	Send alert when speed rises above the set limit	SPEED HIGH	SPEED > XX KN
Settings				
Alert group ETH0	SYSTEM, BAM1,BAM2,CAM1,CAM2	Group to be used for alert messages		
Alert group ETH1	SYSTEM, BAM1,BAM2,CAM1,CAM2			
BAM/CAM SFI	CAXXXX	SFI of the BAM system		
Escalation time	0:30 to 5:00 in 30 second steps			
Categories				
Low speed	Off, W(3032) W+E(3032/1)	Value out of set limits	SPEED LOW	SPEED < XX KN
Highspeed	Off, C(3033)	Value out of set limits	SPEED HIGH	SPEED > XX KN
System Error	Off, W(3015) W+E(3015/4) C(3016)	Error causing system to stop measuring W + E shows escalation from warning to alert (Cat B) after escalation period.	SYSTEM ERROR	SENSOR COMMUNICATIONS
Internal error	Off, W(3062), C(3063)	Non critical error	INTERNAL ERROR	SETTING DISRUPTING SYSTEM
Power Failure	Off, W(3022)	A power supply has lost power (see also relay)	POWER FAIL DC	VOLTAGE TOO LOW < 12V VOLTAGE TOO HIGH >24V

Power Reduction	Off, W(3032)	Power supply out of design limits	POWER REDUCTION	
unsynchronised clock	Off, W(3119)	external clock input missing	UNSYNC CLOCK	NO EXTERNAL CLOCK INPUT
Unrecognised network	Always connected C+W(3059/8)	Unrecognised cable device is attached to network	NETWORK	Uncontrolled network connected

Non critical errors could be 'cannot connect to sensor' the error type is shown in the diagnostic screen

8 Calibration

The calibration setup is split into installation offset, speed, and auxiliary calibrations.

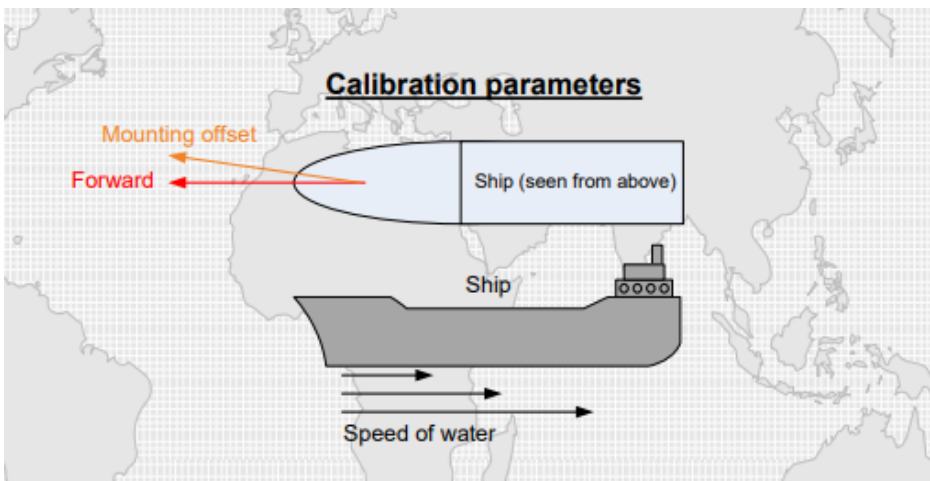

Sensor calibration can vary at different speeds of the vessel due to drag of the water, or bubble / Turbulence formation, so the system has possibility to calibrate the sensor at 5 different speed zones. Each can be adjusted manually, using a sea test of 2 legs, or automatically using inputs from other approved systems.

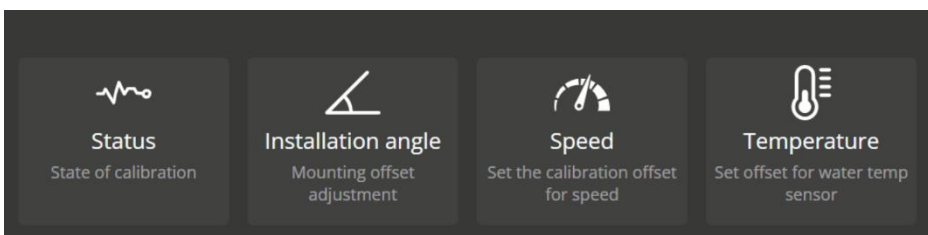

8.1 Status

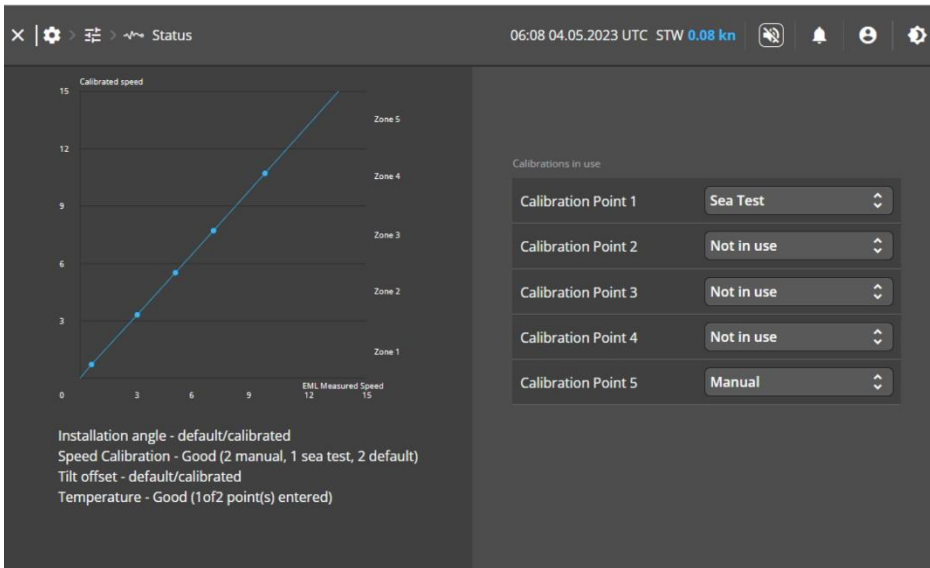

The Status screen shows the status of the calibrations on the left and shows the current speed graphs five points. This graph usually shows a reasonably straight line with a slight increase in the gradient of the curve at faster speeds. The five points on the right allow the user to select between the use of Default values (calculated by using the other points), Sea test ,calculated during a sea test (see below) Manual used by manually adjusting or using the GPS value at that time, or Auto* using historical data from the sensor and GPS.

Normal usage is to set a manual value on first sailing, perform a sea test when possible and then switch to auto (*coming soon) after some months of sailing.

In most cases one sea test at the highest speed will be enough to get the system within its accuracy requirements, more calibrations will improve this.

8.2 Installation angle



Offset adjustment adjusts any angular mounting variations relative to the ship. The adjustment can be up to +/-180 degrees; however some sensors do not have as good resolution at higher adjustment angles so installation should aim to be as close to zero as possible.

Five zones are selectable here, speed through water sensors may experience water is dragged at slightly different angles at different speeds, but generally a single value is enough.

Sea tests will measure the installation offset, for the speed zone calibrated.

8.2.1 Speed Calibration

The relationship of the Real speed of the vessel, relative to the measured speed from the sensor can vary with the speed of the vessel or the mounting angle of the sensor. Speed through water (STW) measurement tend to vary much more with speed than Speed over ground (SOG). This variation can change with time as the hull or sensor gets growth and water drag is changed. When the hull or sensor is cleaned, the calibration will change again. EML systems which measure at the sensor surface are more sensitive to this than Doppler sensors which measure remotely.

MANUAL / GPS SPEED CALIBRATION

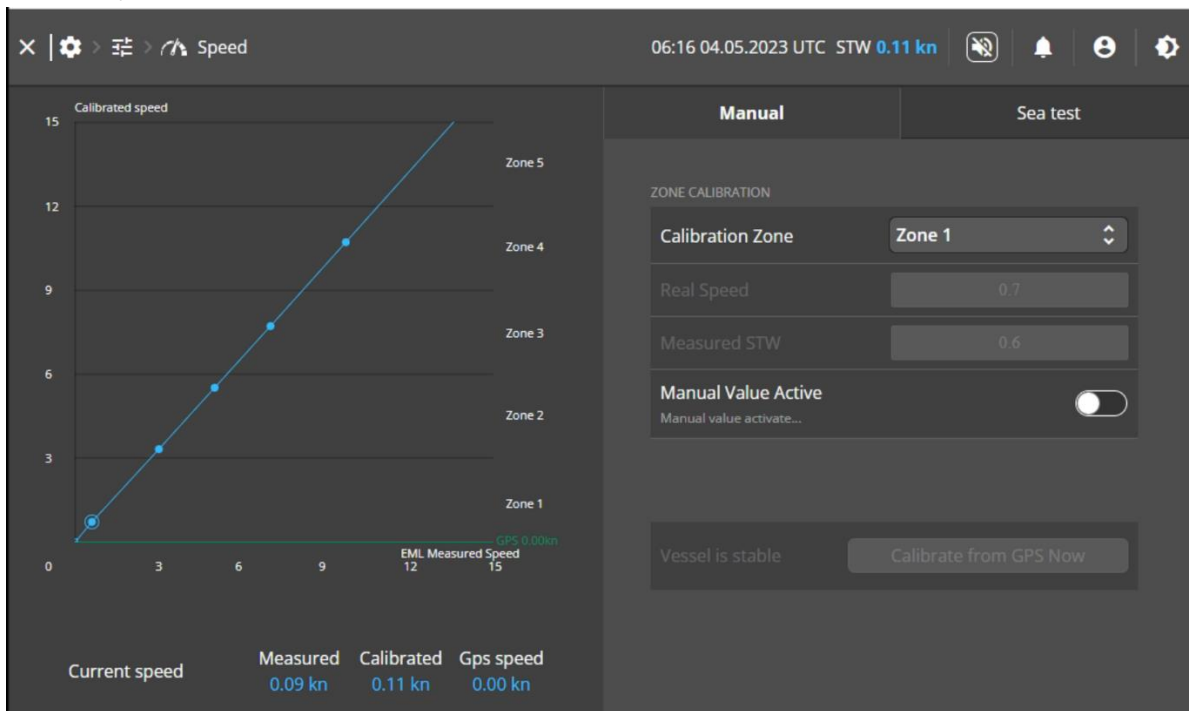

If you wish to adjust an individual speed offset the right side of the screen shows the current values, these are either previously adjusted manual settings, default or generated by the sea test. If not active, these can be adjusted by activating the desired speed zone and adjusting the real speed (from GPS) and the measured speed from the sensor.

The simplest way to do this is to adjust the speed when the vessel is sailing at that speed. In this case, when the vessel is sailing in a stable speed and heading the 'Calibrate from GPS Now' button will show and when pressed, will replace the values in the selected zone with those measured now.

This assumes no current. If there is a detectable current, then only the sea test should be used.

8.2.1.1 Sea test speed calibration

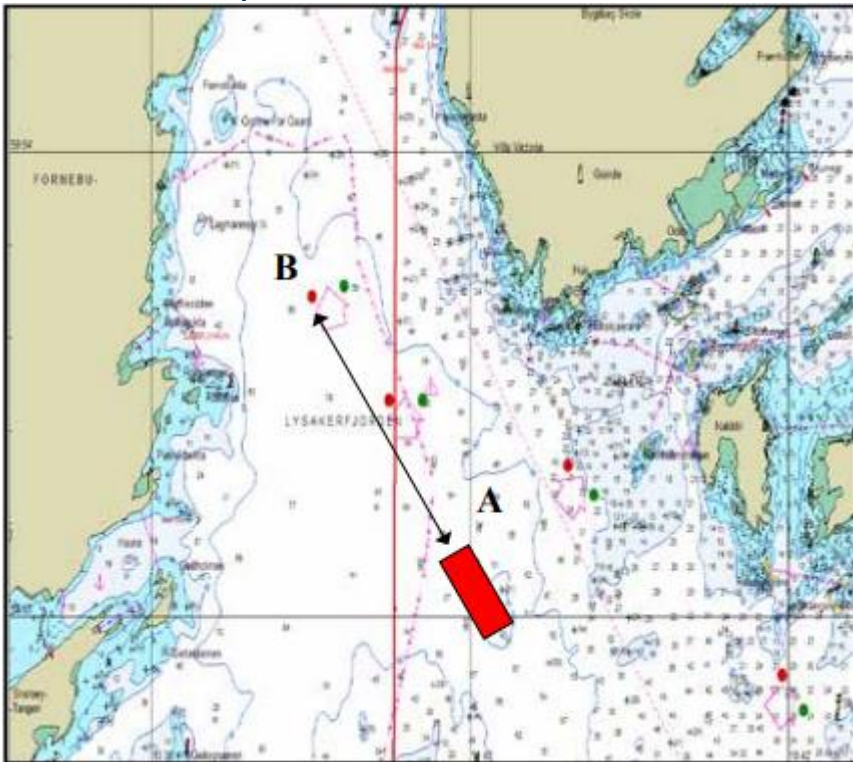

To get the most accurate calibration, the system needs to compensate for current within the sea. The simplest way to do this without having a reference system is to sail the vessel in opposite directions within the same part of the sea so that the vessel measures the current in opposite directions and cancels it out.

Turning the vessel can be a big and expensive procedure. To minimise this, the system allows up to 3 calibration speeds to be performed within the same leg.

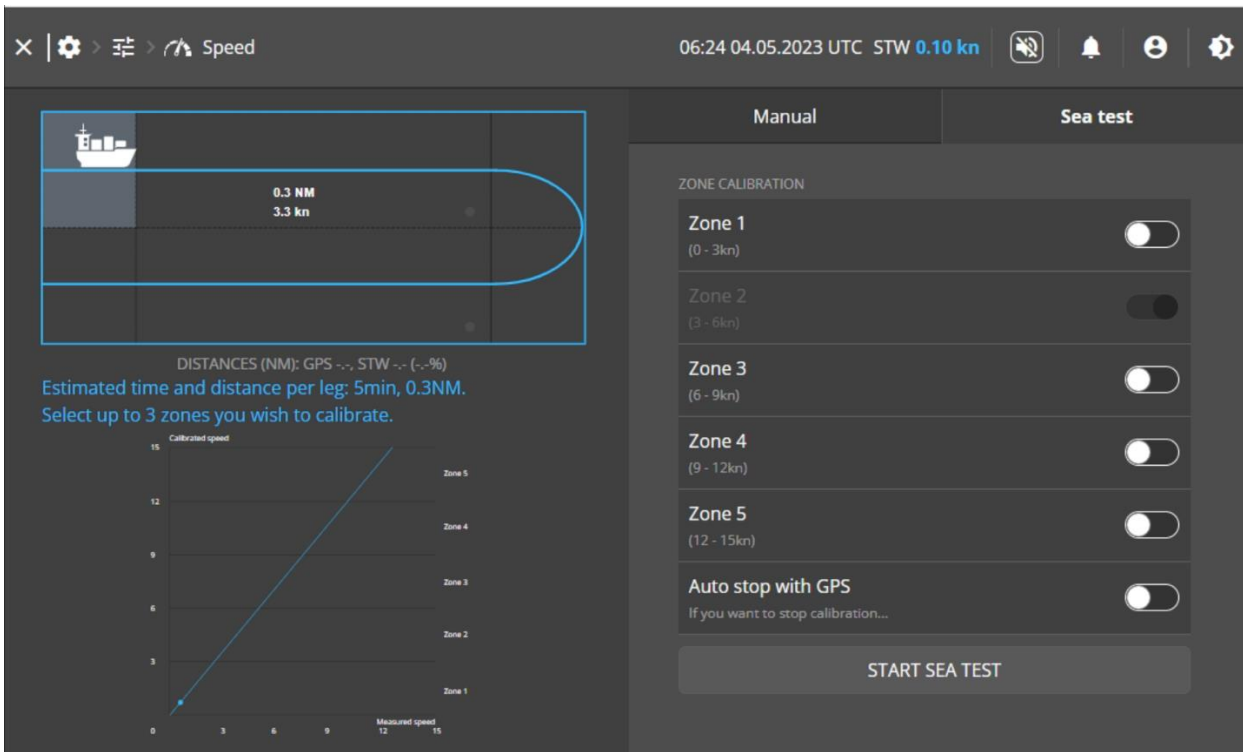

Sea calibrations should be made at max speed and normal operational speeds. Select the desired speed zones to be calibrated, and then follow the onscreen instructions. The calibration should take place in an area with low current or stable current. The opposing legs should be in the same area, preferably not in the wake of a previous leg.

The system will give the user an estimate of the time and distance to make this calibration.

The use of a GPS input is advised to help the user make the legs the correct length (Activate Auto stop with GPS). If GPS is not available, the system will require the user to use the chart to find the correct position to start and stop the calibration.

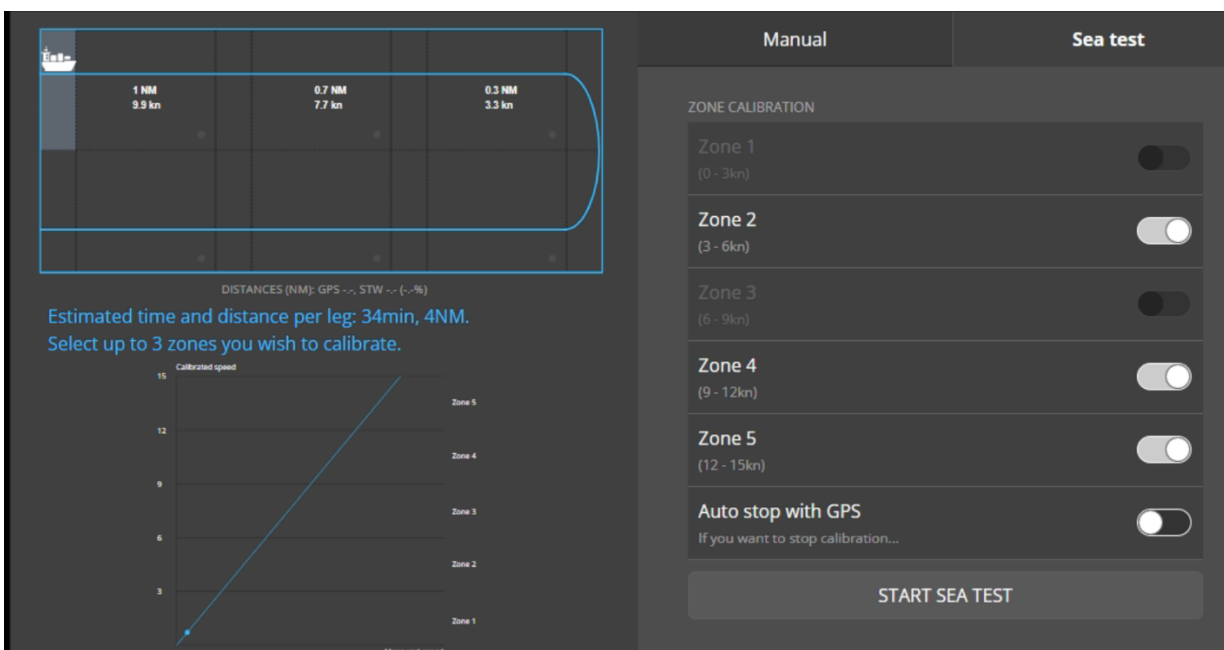

Once selected, the vessel should move into position for the start of the leg and accelerate to the correct speed.

On start the vessel will show the following screen

The screenshot shows the SKIPPER interface with a navigation plan and a status panel. The navigation plan consists of three legs with the following distances and speeds:

Leg Distance (NM)	Leg Speed (kn)
1 NM	9.9 kn
0.7 NM	7.7 kn
0.3 NM	3.3 kn

Below the navigation plan, the status panel provides instructions and a table of current ship status.

INSTRUCTIONS

STABILIZE VESSEL AT SUGGESTED SPEED AND HEADING

Increase Speed (MIN 8.9kn, MAX 10.9kn)

Speed Stability: Stable

Stabilize At Desired Heading

Heading Stability: Turning

CURRENT SHIP STATUS

	NOW	MIN	MAX	AVERAGE
Gps Speed (kn)	0.00	8.9	10.9	9.9
Uncalibrated Speed (kn)	0.02	8.9	10.9	9.9
Calibrated Speed (kn)	0.01	8.9	10.9	9.9
Heading (°)	155.84	-180	180	0
Rate of turn (°/min)	-6.00	0	2	0

On the right side of the interface, there are two tabs: 'Manual' and 'Sea test'. Under the 'Sea test' tab, there are three buttons: 'START', 'SKIP', and 'CANCEL SEA TEST'.

The status in the middle field will turn green when the desired stability is achieved. Once green you are ready for the first leg. Press 'START'.

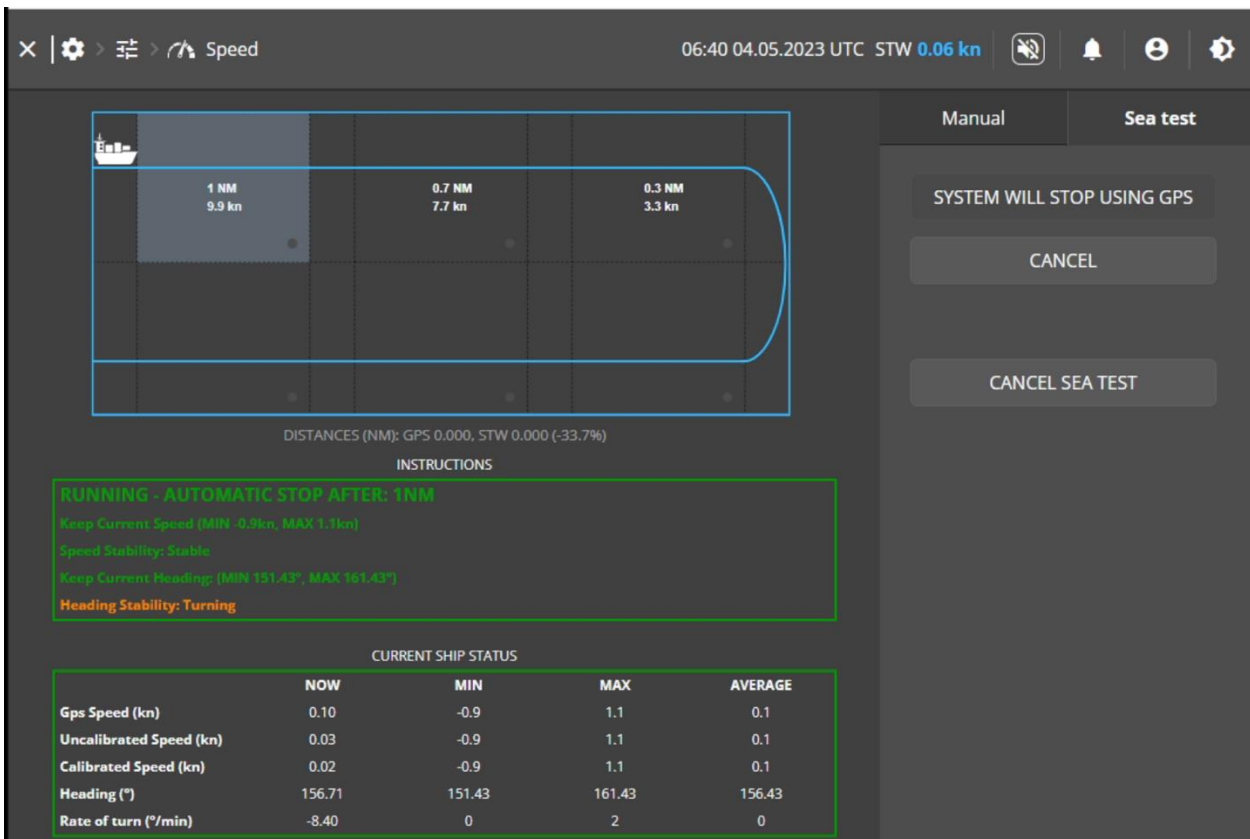

The vessel sails at the same **Heading**, until the correct distance is reached. It will then stop (be manually stopped by the crew if GPS is not available)

The vessel then accelerates/decelerates to the next speed and repeats. After all speeds in the leg are performed the vessel should turn 180 degrees and sail in the opposing heading. Repeating the legs in the opposite direction. After each leg the user will be asked if they accept the calibration or not. At this stage the data will be transferred to the calibration tables

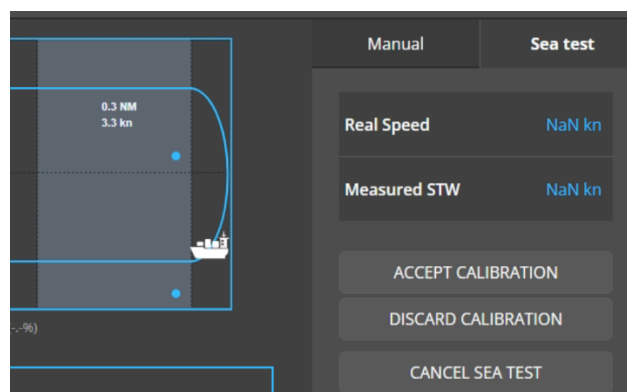

After the calibrations in the second leg are performed the system will show a summary of before and after.

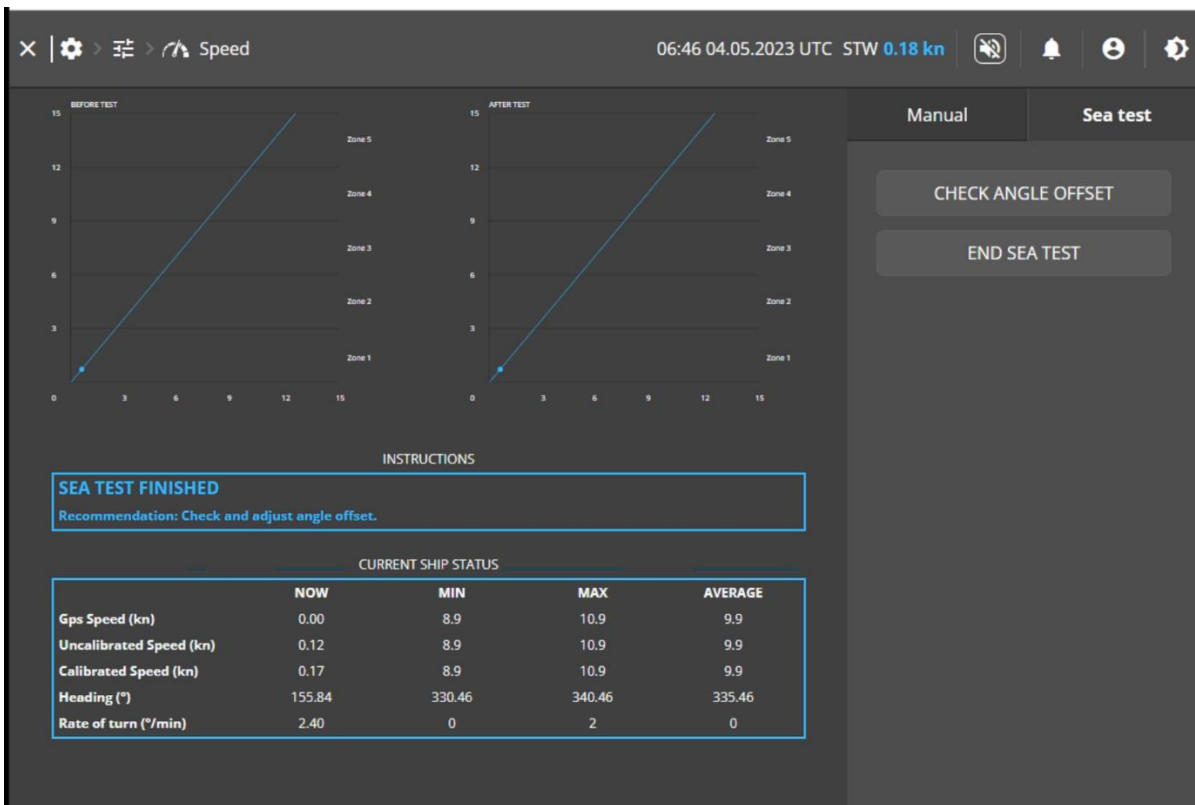

The user can then decide to check the installation angles measured during this sea test. If these seem wrong, they can be ignored and manually adjusted to a more appropriate value.

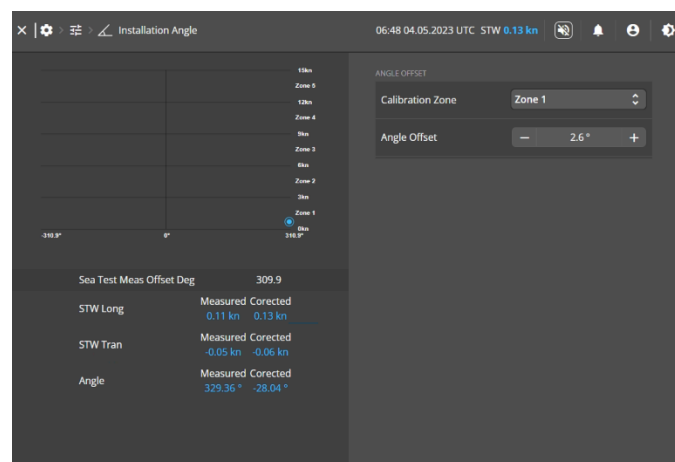

8.3 Temperature offset

Temperature adjustment screen shows the last 5 hours measurement and allows the user to add an offset by adding the actual water temperature using a reference device on reading from the coolant intake device.

8.4 Auto calibration

this is not yet implemented and will be part of later releases of the product

9 Verifying, Supporting and Maintenance of your system

9.1.1 Diagnostic screen

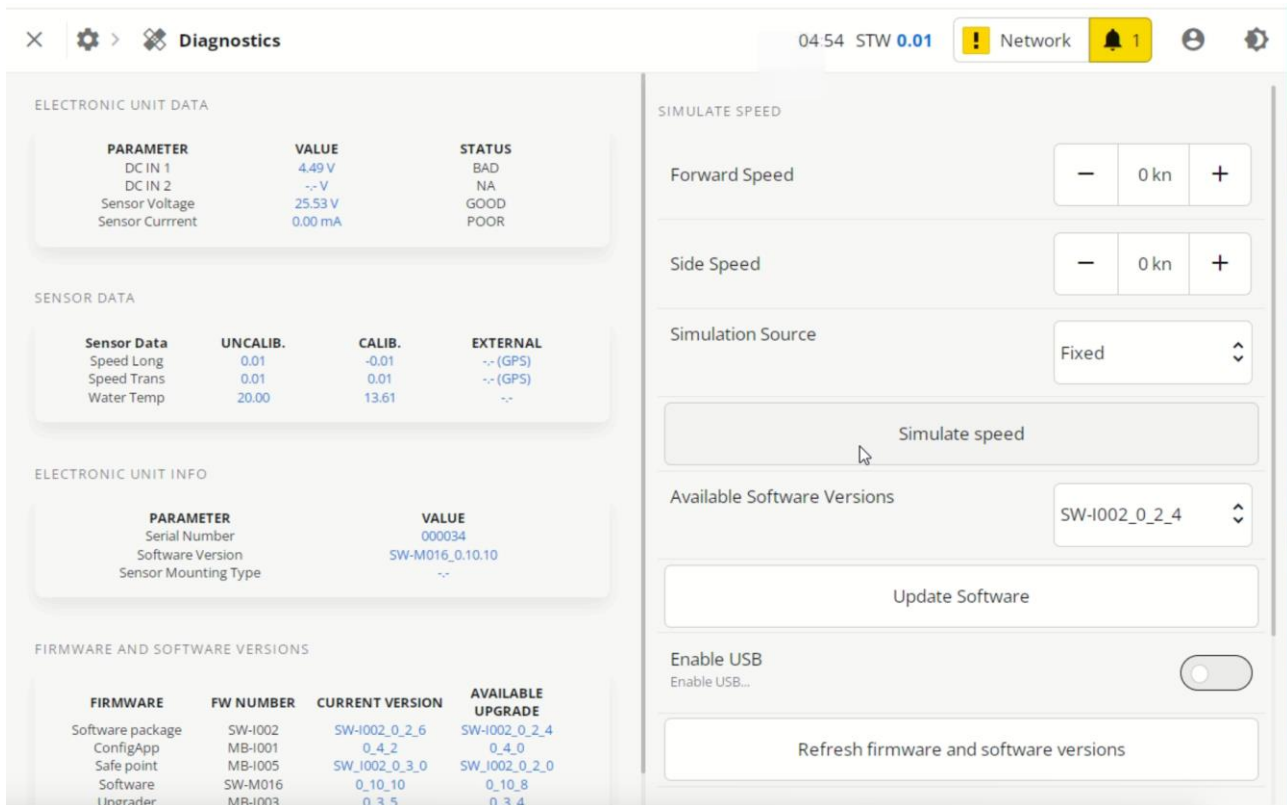

The screenshot shows the Diagnostic screen with the following data:

PARAMETER	VALUE	STATUS
DC IN 1	4.49 V	BAD
DC IN 2	-- V	NA
Sensor Voltage	25.53 V	GOOD
Sensor Current	0.00 mA	POOR

Sensor Data	UNCALIB.	CALIB.	EXTERNAL
Speed Long	0.01	-0.01	-- (GPS)
Speed Trans	0.01	0.01	-- (GPS)
Water Temp	20.00	13.61	--

PARAMETER	VALUE
Serial Number	000034
Software Version	SW-M016_0.10.10
Sensor Mounting Type	--

FIRMWARE	FW NUMBER	CURRENT VERSION	AVAILABLE UPGRADE
Software package	SW-I002	SW-I002_0_2_6	SW-I002_0_2_4
ConfigApp	MB-I001	0_4_2	0_4_0
Safe point	MB-I005	SW_1002_0_3_0	SW_1002_0_2_0
Software	SW-M016	0_10_10	0_10_8
Upgrader	MB-I003	0_3_5	0_3_4

The Diagnostic screen has several useful functions to help diagnose problems. If serious problems occur, this can be indicated in the alerts page as caution or warning. The left side of the page shows the running status of the system, showing internal measurements such as voltages and currents with their advised limits.

The middle field shows the installation parameters with software and firmware versions, and installation selections.

The bottom field shows the runtime status of the sensor, indicating the measured values, the values after calibration, and the equivalent values from the auxiliary inputs (if available). Note this system measures Speed Through Water (STW), which is similar but not the same as Speed Over Ground (SOG) given by the reference system.

This page gives a good summary of the system, and a photo of this page will be great help if requesting help from a service centre.

9.1.2 Simulate speed

The System can simulate a speed to the outputs. The Required speed can be entered and the type of variation of the speed can be selected.

Simulation source	Description
Fixed	Send the speeds as defined in forward and side speed
From GPS	Send the GPS SOG value as forward speed
From file	Send data from a simulation file called Simulate.enc , as a software upgrade from the service software. (Not yet implemented)

9.1.3 Software upgrade

Software upgrade is performed using files that can be downloaded from the SKIPPER website. These files contain software and firmware required within the system and are compressed and encrypted to meet modern cybersecurity standards. The Files can be placed straight into the unit using a LAN connection by the SKIPPER service software, alternatively the service software can be used to make a file on a USB memory stick. This can be safely inserted into the unit, and the user can trigger this software to be loaded onto the unit by selecting the USB on the diagnostic page under upgrade. In this case the files will be verified and copied onto the public part of the system and the user can trigger an upgrade.

In some cases, the upgrade can be triggered remotely, in this case the service software will require the service or admin level username and password.

The system will keep a copy of the replaced software and configurations. This can be retrieved by service software or SFTP, for diagnostics. It can also be re-installed in the system by the user if required.

9.1.4 Simulate alarm

This function activates one of each selected alert, warning, caution, to allow a BAM system to tackle those alert cases.

9.1.5 Self test

Self-test will run some diagnostic tests within the unit. To check everything is functioning correctly the following tests are performed:

SELF-TEST INFO				
TEST NUMBER	TEST PERFORMED	RESULTS	LIMIT	STATUS
1	CPU Load	24.44 %	70.00 %	PASS
2	RAM Usage	27.82 %	90.00 %	PASS
3	ETH0 Load	7.62 Mb/s	50.00 Mb/s	PASS
4	ETH1 Load	0.00 Mb/s	50.00 Mb/s	PASS
5	DCIN 1	0.00 V	18-31 V	FAIL
6	DCIN 2	24.13 V	18-31 V	PASS
7	Sensor Voltage	23.66 V	18-31 V	PASS
8	Sensor Current	497.32 mA	10-200 mA	FAIL
9	Calibration Stability	8.51 kn	3.00 kn	FAIL
10	Sensor Stability	0.00 kn	1.00 kn	PASS
11	Cleaning Status	6.76	0.50	GOOD

test	Result	Status	Comment
CPU load	Value %	Pass / Fail (<70%)	The current load on the CPU's
Memory Usage	Value %	Pass/ Fail (<90%)	The amount of RAM in use
ETH0 Load	Value Mbps	Pass, Warning (>50Mbps) /Fail (>70Mbps)	The total load detected on the Network 0 (100Base10)
ETH1 Load	Value Mbps	Pass, Warning (>50Mbps) /Fail (>70Mbps)	
DCIN 1	X.X V	Pass/ Fail / NA (18V<X<31V)	The detected Voltage on input 1 *
DCIN 2	X.X V	Pass/ Fail / NA (18V<X<31V)	The detected Voltage on input 2 *
Sensor Voltage	X.X V	Pass/ Fail / NA (18V<X<31V)	The detected Voltage on sensor output*
Sensor current	XX mV	Pass/ Fail / NA (10mA<X<200mA)	The detected Voltage on sensor output*
Calibration stability	Value now	Pass (<3kn) / Fail / Poor	The averaged speeds in the last 24 hours are compared with the GPS values, if the difference is too much this will fail, indicating the system should be recalibrated.
Sensor stability	Max deviation	Pass (<1kn) / Fail / Poor	The raw sensor values are monitored and the difference from sample to sample is measured. If too great the sensor is probably unstable
Cleaning status	Value	Pass >0.5 / Fail / Poor	An averaged difference between the sensor raw values for speed, and the SOG value for speed is checked, and if the difference is too large (more than double) the sensor needs cleaning.
* NA is indicated if the input is not in use and disabled in the system setup menu			

9.1.6 Hardware Reset button

The System has a hidden button accessible with a pin on the back of the display unit. Pressing this will downgrade the software and configs to earlier safe versions.

9.1.7 5 second press

A press of 5-30 seconds will install an older safe software and firmware version. The unit should then work and can be upgraded again. Settings for IP and SFI are kept.

9.1.8 30 second press

If all else fails a press of over 30 seconds will return the unit to its pre-system selection state. In this case the option number for the system must be entered, and IO configuration. Software must also be entered after this reset.

9.2 Logging screen

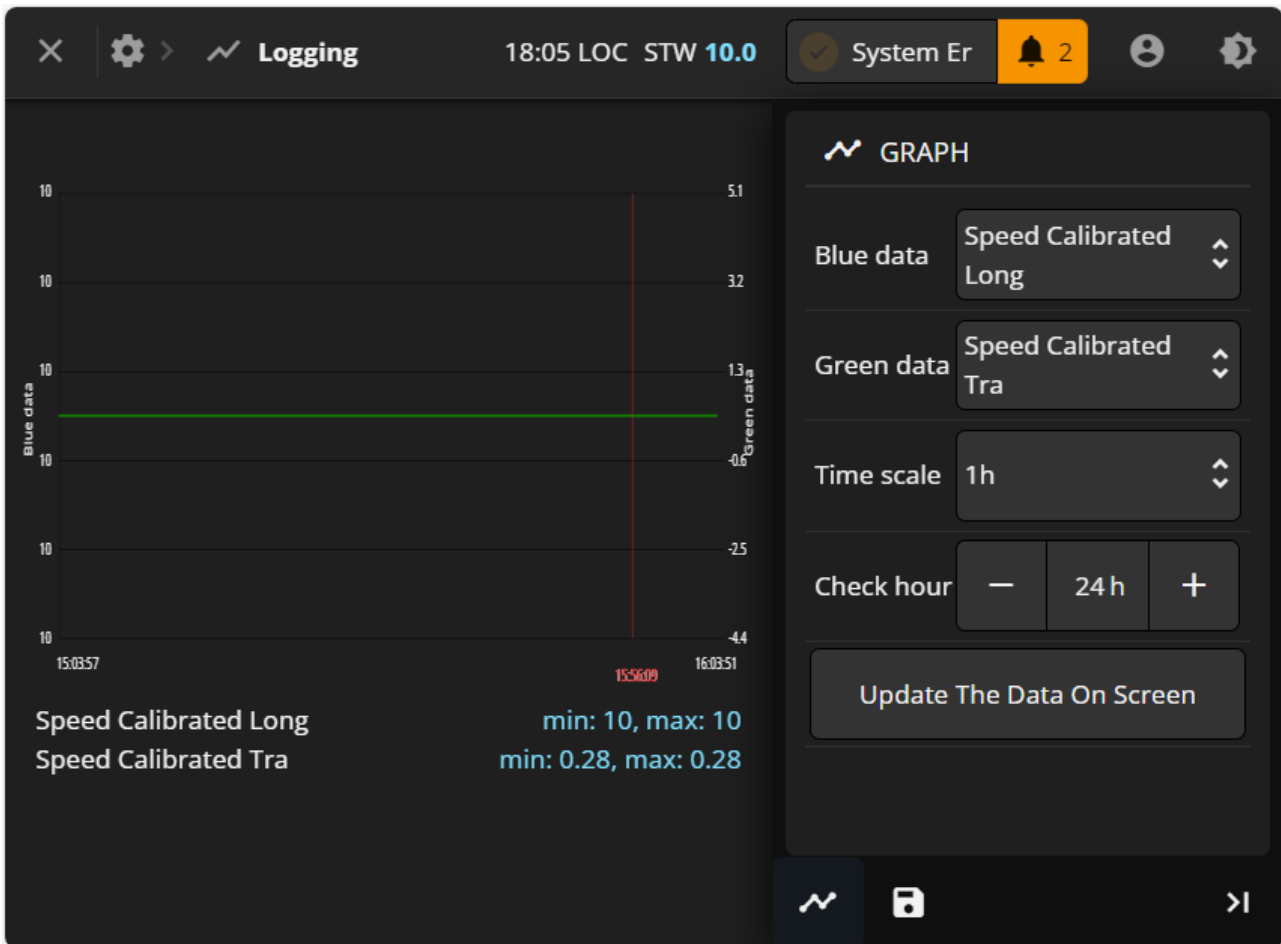

9.2.1 The graph

The graph can show data from the last 24 hours. The graph lines can be selected on the right, showing either all 24 hours, or a single hour, this can be offset to show a particular time. After adjusting the settings pressing the update button will load that data.

The user can then press on a particular point to see the data values and the associated aux values (in the table below the graph) at that point.

The graph can be maximised by minimising the side menu.

9.2.2 Logging options

Unless specifically told not to, in the advanced system settings, the system will continually log data it is receiving and generating. This data is logged for as long as there is designated memory space available. The

user can select whether to log for a period and then stop , keeping only the latest file. Or whether to get rid of the oldest files and overwrite with new.

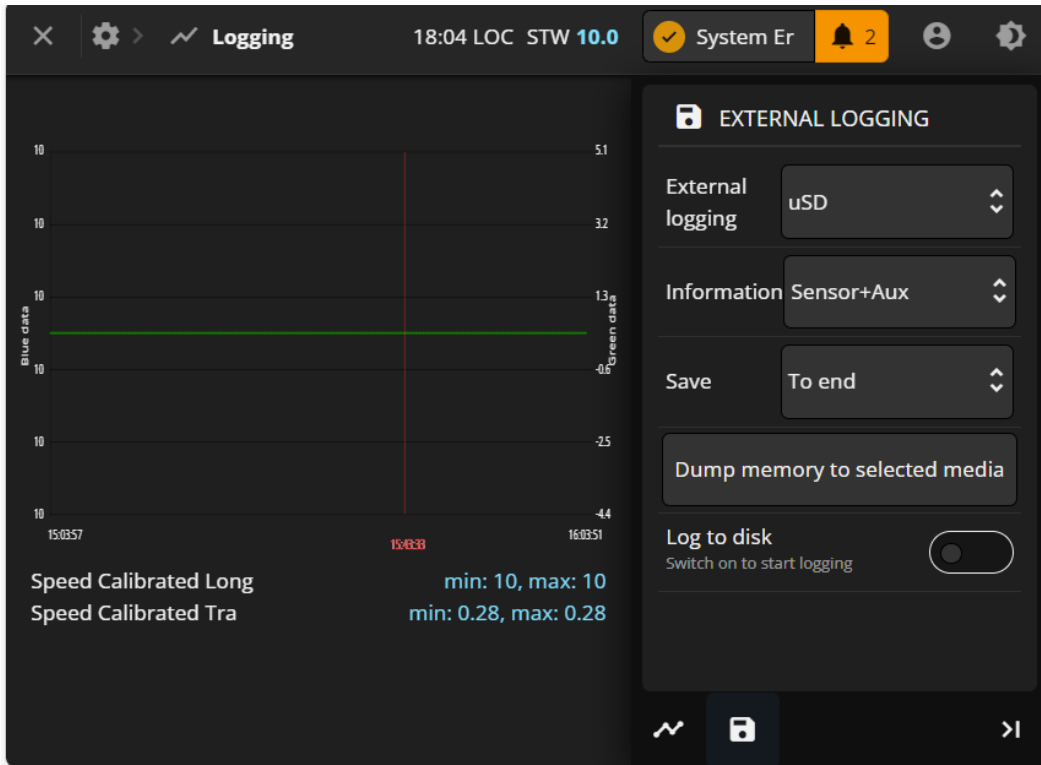

In addition, a USD or microSD disk can be used to log. In this case the old files can be dumped onto the disk, and then new files are written directly.

Saving Options:

- External logging - Selection of media to write to (USB, SD, None)
- Information - Logging of Sensor and auxiliary data, sensor and diagnostic files or the Sensor, diagnostic and Raw data.
- Save 'Loop continuously' or run 'to the end' of the memory, but keep the last file updated.

Logs can be copied to USB, or collected directly using the SKIPPER service software windows software



Important! The USB outputs are not isolated, as this is implied in the USB standard. However, some USB peripherals connect Power 0V and Chassis. In this case a Earth leakage may occur and in the worst case, this could damage the system, and cause an alert.

To prevent this , check your USB devices that will be long term installed, and if not isolated, use the SKIPPER isolator GC-202-SA or equivalent. (isolating both signal, and power)

9.3 Periodical maintenance of the system

9.3.1 Display

Displays can be cleaned with a microfiber cloth, and normal display cleaning fluids.

9.3.2 Electronics

It is advised to upgrade software if a newer, recommended version is available (available on SKIPPER web). Visually check connectors and cable anchors.

9.3.3 Valves

O rings and exposed gaskets should be inspected / greased (with silicone grease) and preferably replaced, when a valve is opened.

Moving parts can be greased using a general purpose marine grease.

The Gate of a Gate valve should have a clean mating surface, if it is not clean, some extra leakage may occur during sensor replacement, this does not have any consequence in normal use.

9.3.4 Tanks

No maintenance required. The provided red pain, is only a primer. Installed tanks should be painted (BUT NOT THE SENSOR).

9.3.5 Mounting

Sensors must always be flush to the hull. Growth around a sensor should be kept to a minimum.

Ensure you remove masking from sensors if the hull has been coated. Take a photo of the mounting before undocking.

9.3.6 Sensor/transducer

The plastic of the sensors can be damaged if they are scraped with a hard object, we therefore advise to remove large objects and then use a hard plastic scraper to remove as much of the remaining growth as possible. You must not use sandblasting or high-pressure cleaning tools on the sensors/transducers.

The EML sensor has metal (Monel) sensors in the front. As the vessel gets growth these pins can be covered, and the speed will show lower. This error can be removed with calibration, but if the calibration factor is more than 2x times we recommend cleaning the sensor. This time can vary from 6 months to 2 years depending on the water temperature and time spent alongside.

10 Runtime displays and setup

The runtime display is intuitive with the following features:

10.1 Runtime screens

3 screens are available Open sea, Coastal and Docking. These can be set up to show optimal data in these three operational modes. The modes can be changed using NMEA command (to follow). The screens all have the following elements.

10.1.1 Top bar

Showing the page being shown, the system type, the time and date, the primary data of this system, silence alerts button, alert dropdown, user management, and dimming options

10.1.2 Dimming

The dimming menu allows adjustment of the pallet; Bright, Day, Twilight, Night, this can also be adjusted remotely using the DDC dimming command.

The brightness can be changed on the display itself or on remote displays. Dimming is local to each display. Adjustment of the default backlight setting for each pallet can be adjusted using advanced settings in this menu.

If the display has been dimmed down so low that the content is not visible. Press and hold in the middle of the screen to lighten the screen to a visible level.

10.1.3 User setup

Here the user can login. If no user is logged in, the data can be viewed, but settings cannot be changed. At User level, only display function settings can be changed.

Service and Admin level allows other system parameters to be changed.

Admin level allows more users to be added and other user administration.

10.1.4 Alert panel

When an alert is present it can be viewed and handled from this drop down menu

10.1.5 Sidebar

The sidebar shows indirectly relevant parameters. For example speed from other systems, this can be minimised or shown, and parameters are selected in the runtime setup.

10.1.6 Menu

The Hamburger menu symbol shows a drop down, and in this menu the function alert parameters can be changed and daily trip can be reset. You also have access to settings, the manual, System registration information and standby mode

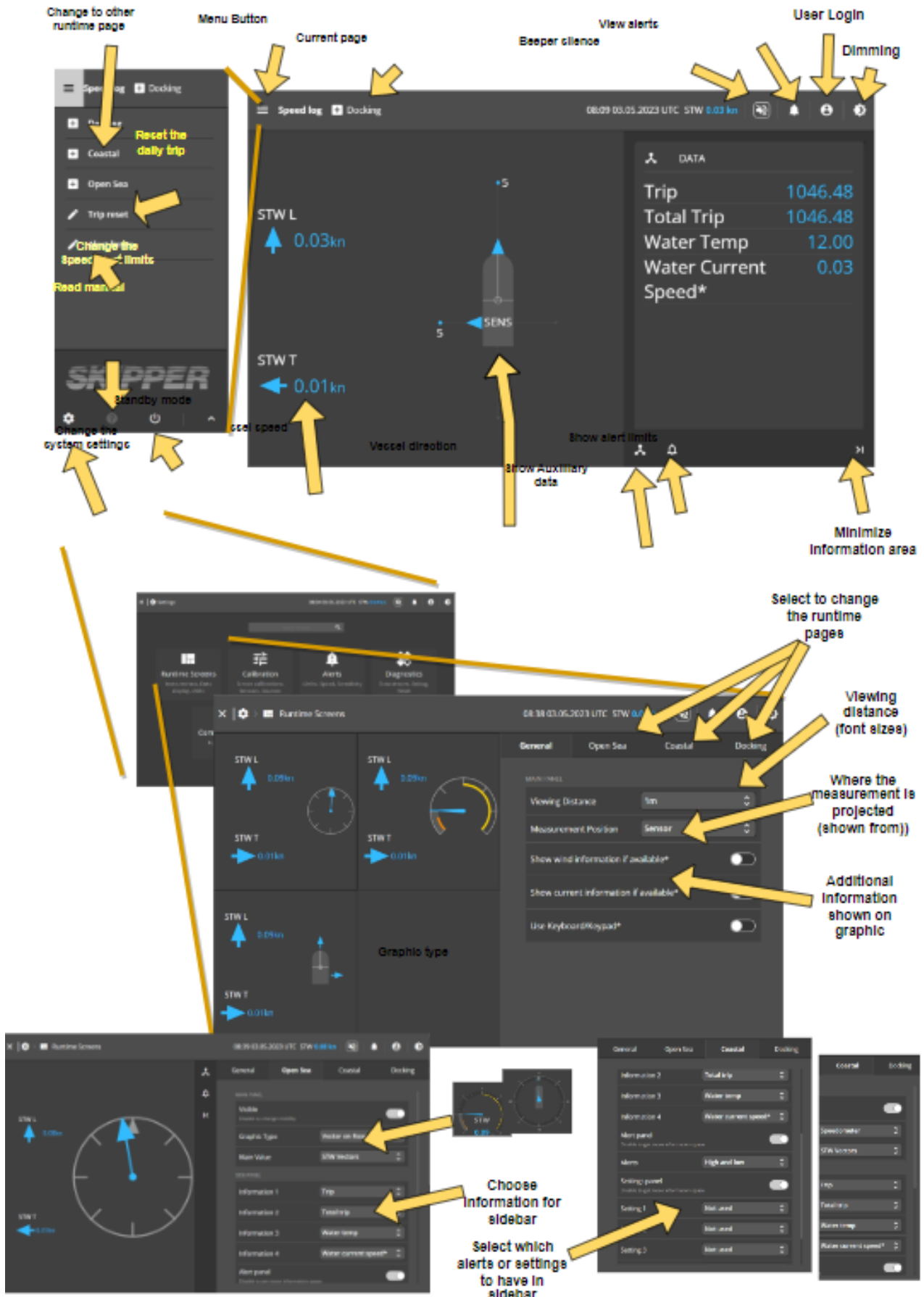

10.2 The Runtime setup

This menu allows setup the 3 operational mode displays by selecting the appropriate tab on the right. The screen on the left shows the display format as selected. On the left you may select:

- The graphic type
- Text data
- Sidebar; The parameters to be shown on the sidebar,
- Alert sidebar select; whether to show the function alert settings
- Settings sidebar, some changeable configuration parameters can be shown.
- Main Data size; selectable Small, Medium and Large for the main data text. Default viewing distance is 0.8 m for the other information / config text.
- Measurement position; the Position of the data can be selected. This can show data from the sensor itself, the CCRP (steering reference point) or from bow and stern.

11 Retrofitting to an older EML224 system

in this case, only the Display must be replaced. The Valve, sensor and JB60 unit can be used. Wiring from the Display to the JB60 will be as shown below:

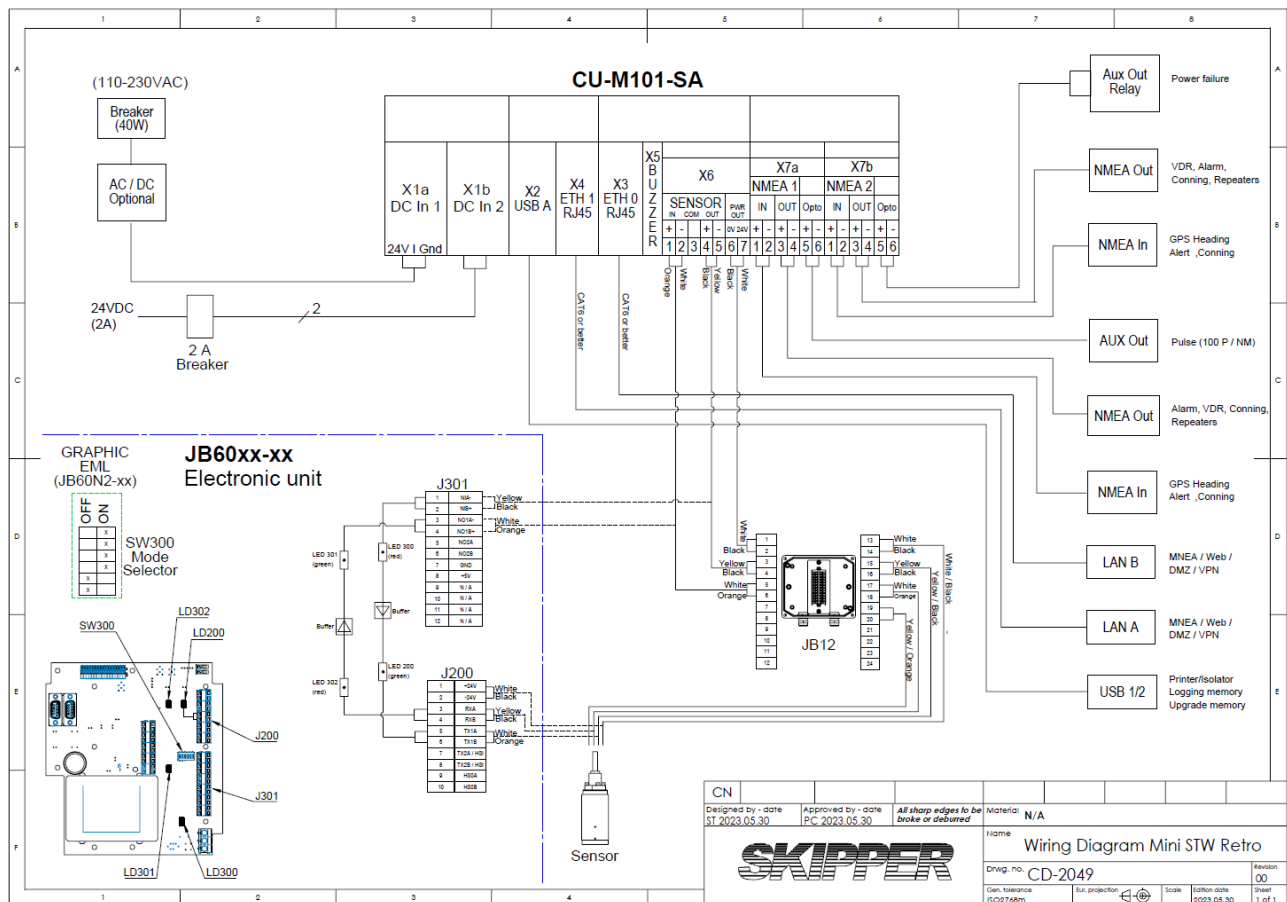

12 Getting started guide

1. Install/Mount the system

12.1 Make a cutout of size 257x 182 in an area of minimum 287x210mm

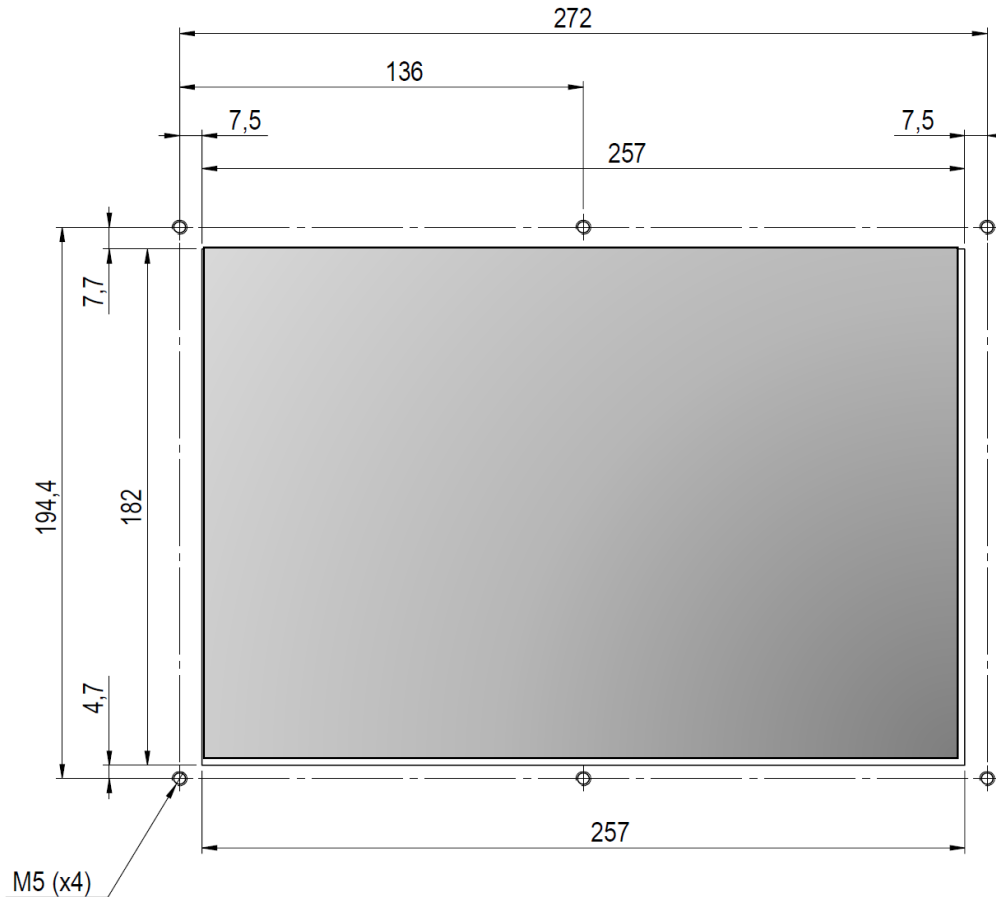

6 x M5 torx Pan head
Screws (ISO 14583) Black

Length 21.8mm , Thread
into the back plate 16.5
mm

Alternative

6 x Self tapping screw for
wood, plastic & non-
ferrous Metal (Requires
Pilot Hole
Depending on the screw
type to be used Thread
the bench plate , Use
Nuts (M5) or drill a pilot
hole of 3mm



12.2 Mount the External beeper (if required)

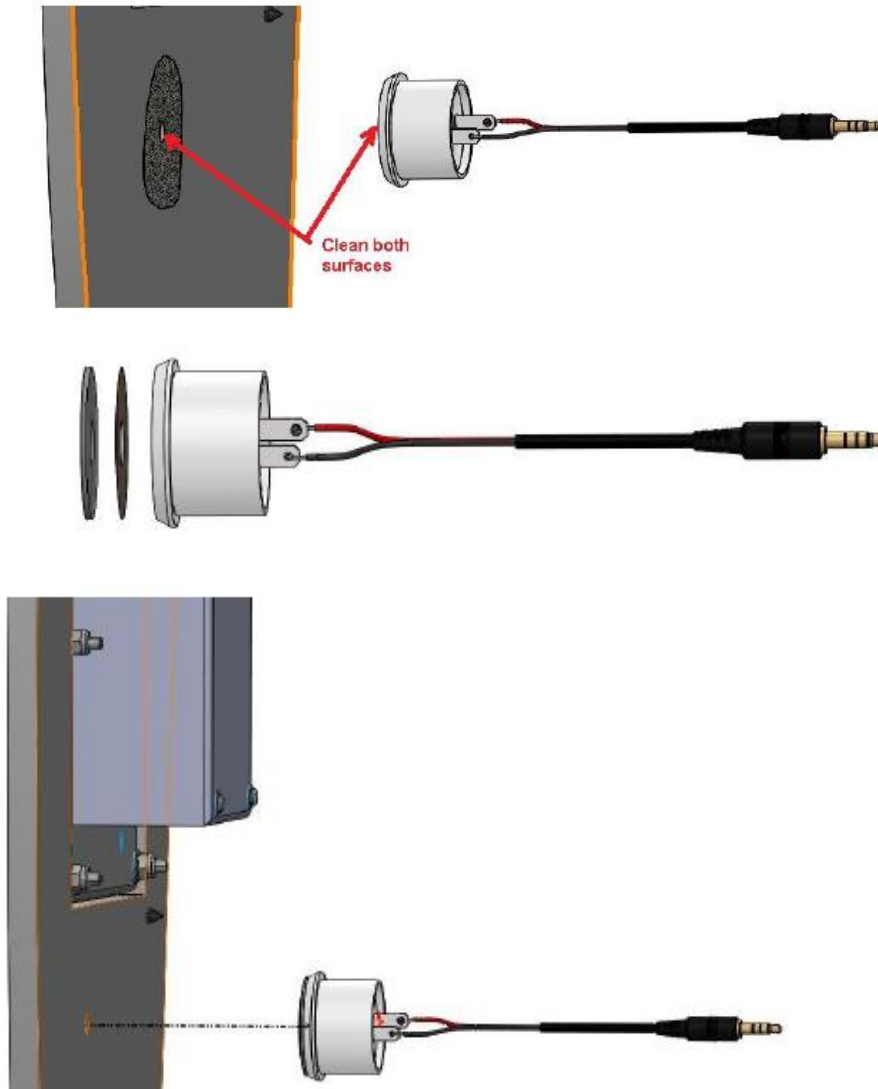

Drill a hole diameter 6.5-7.0mm

Clean both surfaces with attached wipe

Attach the Sticker to the Buzzer

Attah to the rear of the plate , take care to align the holes.

M-KIT-XBEEP-CU-M101-SA

12.3 Attach the IO connectors as required (4.2 in manual)

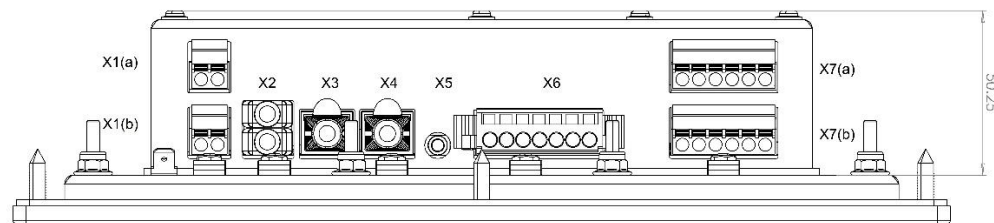
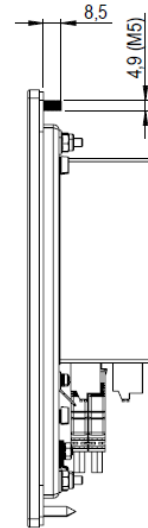
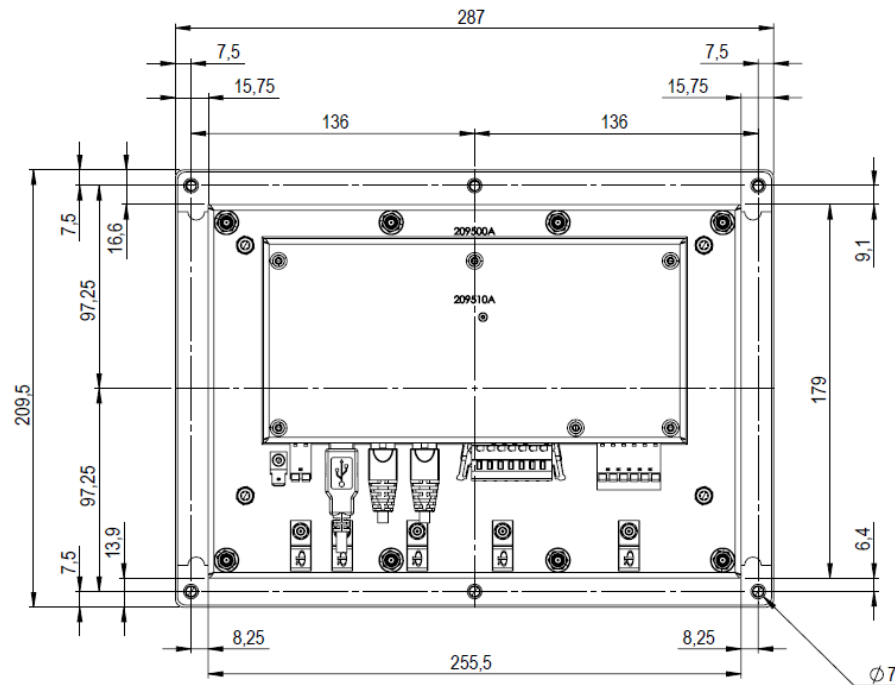

see connection diagram on next page

X1a and X1b 24VDC

Power connector

(Degson 2EDGKD-5.08-02P-14-00A(H))

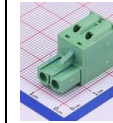

X2 USB Type A (Non isolated)

Use Isolator GC-202-SA for long term USB installations



X3 & X4 RJ45 CAT 6

Cables

Connect to a managed switch or CU-M101-SA unit



X5 M-KIT-CU-XBEEP-00

External Alarm Beeper
3mm mono Jack



X6 Sensor Port

Wago Connector 231-304/026-000
8 Pins



X7-X8 NMEA/ Aux Port

Degson 2EDGRH-5.08-12P-14-00A(H))



Connection of the System (4.2 in manual)

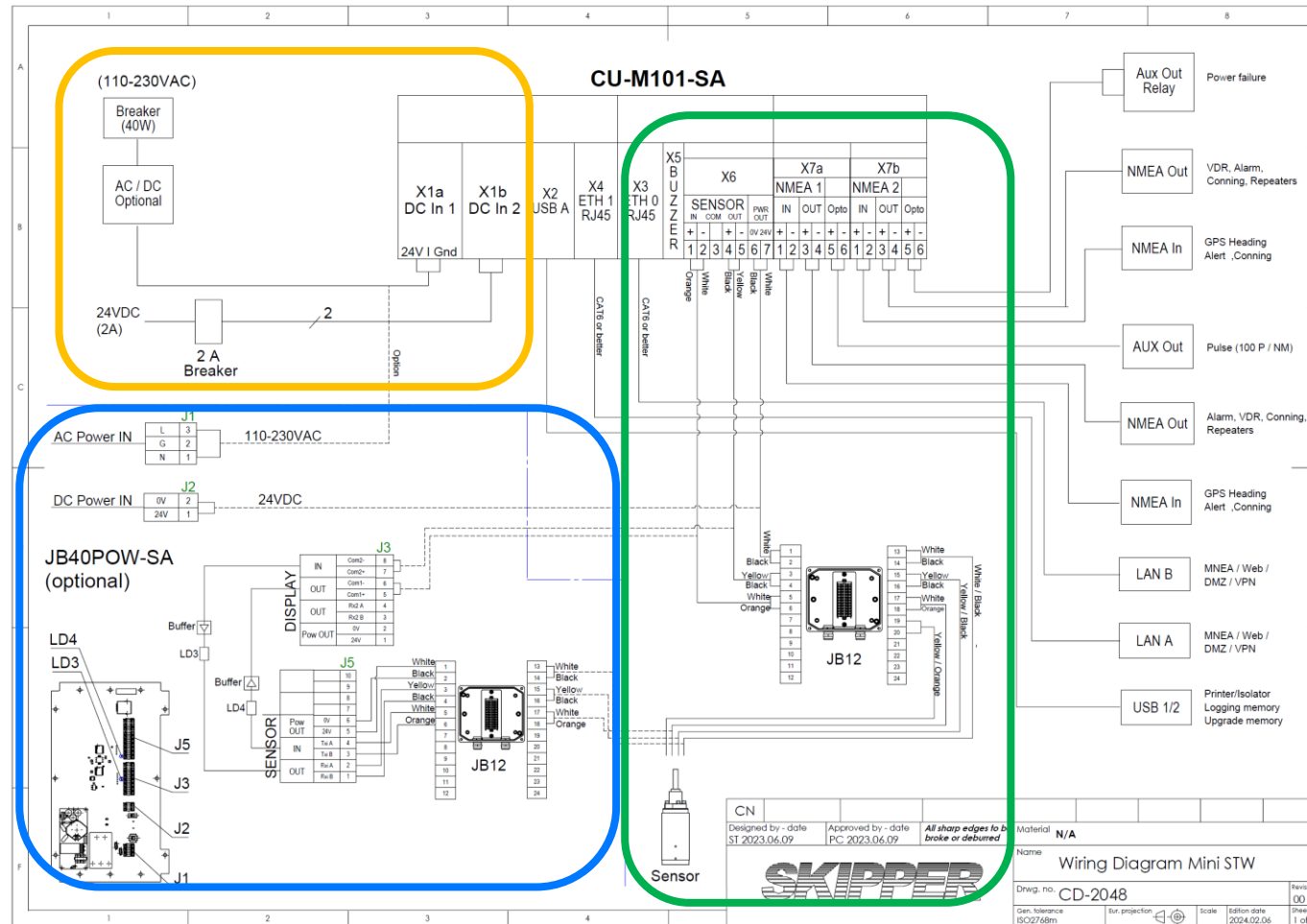

Attach the power connector(s)
Power stability is required.
This is achieved using either

- A secondary power, either 2 24VDC connectors
- by using a UPS as a failsafe

The system requires <20W and Power to the system and the connected JB40 unit (if used should come from a 2A circuit breaker.

Attach the sensor directly

or via a JB40POW unit

If the JB40POW-SA is used locally, AC input to this can generate 24VDC to power the display and the sensor.

In this case disable the Power output in the display System setup menus.

Mount the unit (4.2 in manual)

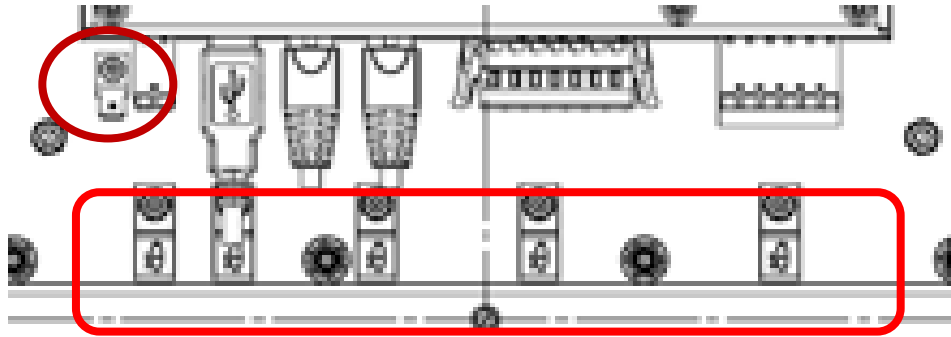

Anchor the cables, using the included cable ties

M-KIT-

Ground The Unit to ships Chassis using the Grounding spade.

Note the serial number of the unit and mount the unit in place

Serial Number: _____ (6 digits)

<h2>Power on and setup (CU-M101-SA, systems not set up at factory)</h2>	
<h3>Turn on the power(s)</h3>	
<h3>Select the Required Product</h3>	<p>If the screen shown is not this, go to 3 Setup the System</p> <p>Enter the serial number (with all leading zeros, 6 digits '000234') go to the define system</p> <p>Click on the QR code, if a Product option is purchased, the code will be available here, If no code is available contact Jotron SKIPPER to purchase the required Product code.</p>
<h3>Ensure Software is installed or download</h3>	<p>If the product option is not shown on the product drop down, Download from the SKIPPER web, and place on a USB stick. Insert the stick. Select the USB media, and try again.</p>
<h3>Assign a system with the option code</h3>	<p>Enter the code, and press install. Installation takes about 3 minutes, and the system will boot into the desired software.</p>

Set up the system

13 Sign in

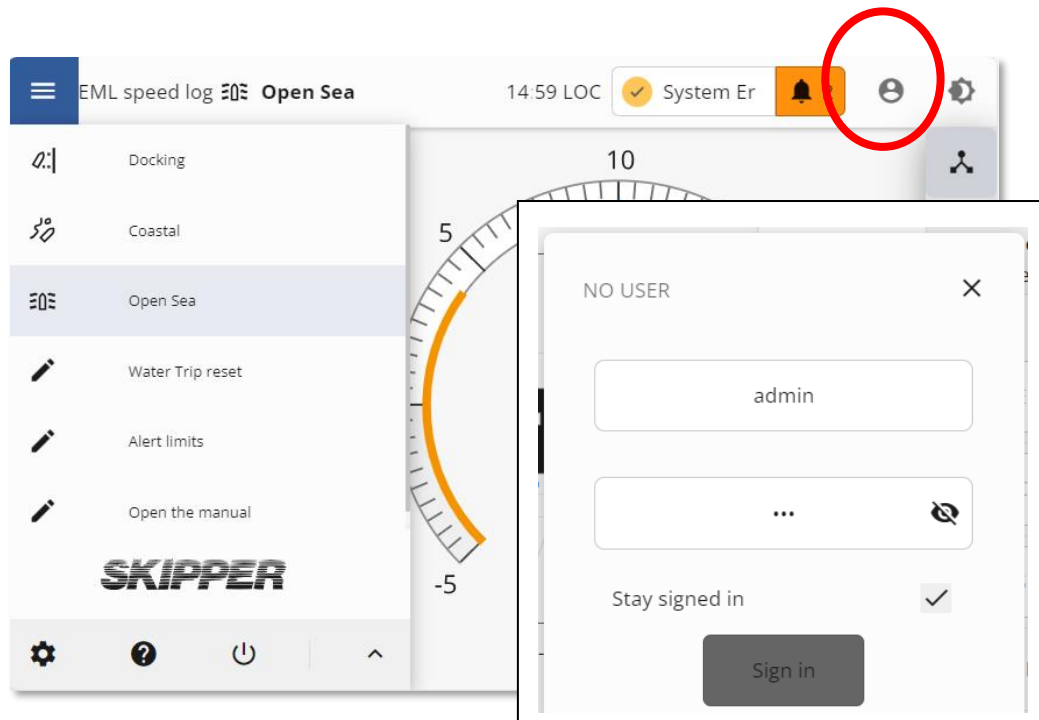

Click on the Users Button

Enter User 'admin' and Password
<serial number> e.g 1234

Check 'Stay Signed in'
And Press sign in.

The system signs in with full access.

(Note, Passwords and users should be
changed before HAT/SAT)

13.1 Configure the system

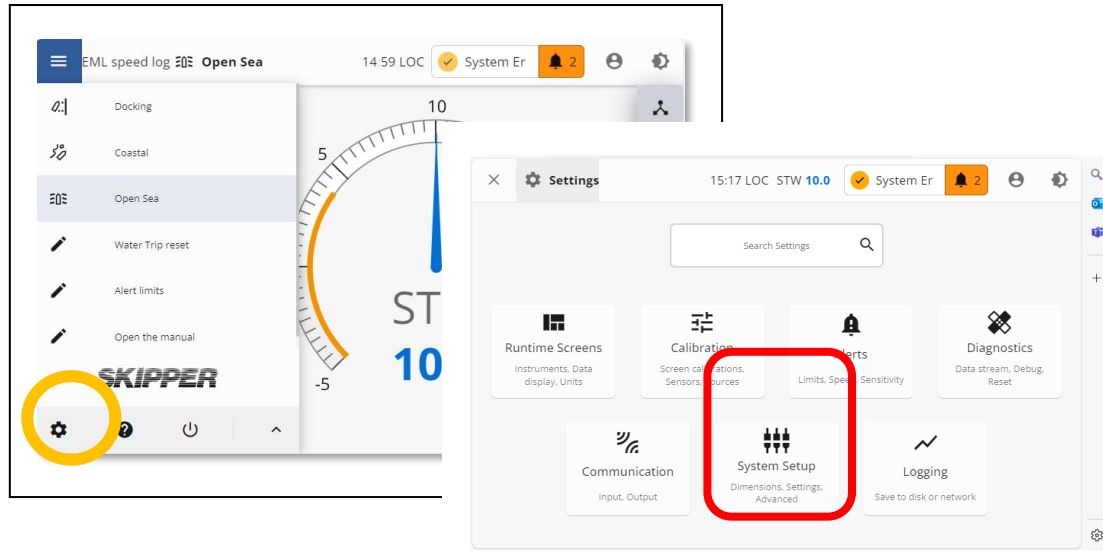

Using the Menu button (top left) select **settings setup** in the menu dropdown

Go to system and enter the vessels parameters.

If you use only one power input, disable the unused one.

If you supply power to the sensor from another unit (JB40POW) disable the sensor Power. (Advanced tab)

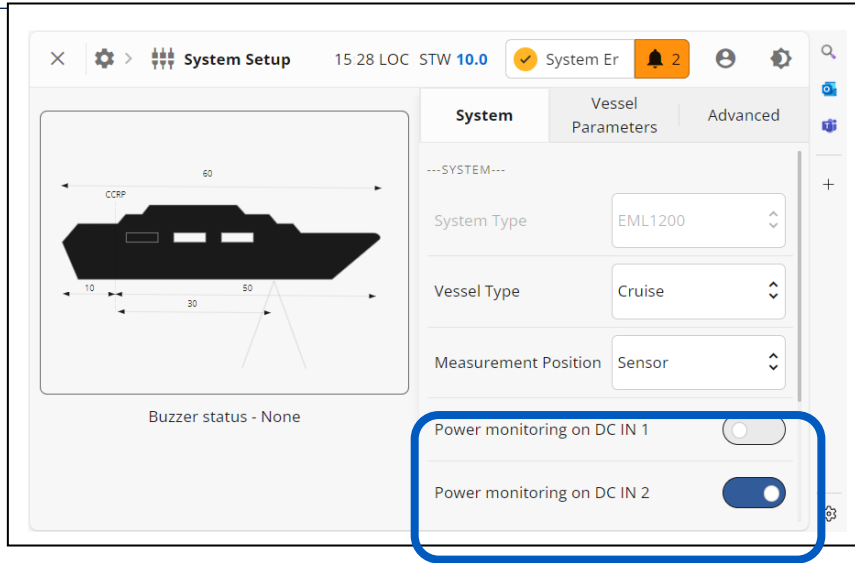

System	Vessel Parameters	Advanced
---VESSEL PARAMETERS---		
Max Speed (kn)	- 25 kn +	
Sensor to CCRP (m)	30.0	
Bow to CCRP (m)	50.0	
Stern to CCRP (m)	10.0	
Vessel Tonnage (GRT)	50000.0	
---REGISTRATION---		
Vessel Identifier	IMO123456	
<small>IMO (required), New Build or Vessel name</small>		
Sensor Mounting	EML224SG-Valve	
<small>Enter the sensor type, and the tank/valve Serial number.</small>		
Bottom mounting serial number	123	
<small>The number stamped into the valve or tank</small>		

System	Vessel Parameters	Advanced
---ADVANCED---		
Filter Type	Normal	
Reverse <small>for 2 direction ferries</small>	<input type="checkbox"/>	
Activate option 2dp <small>option to use 2 decimal places</small>	<input type="checkbox"/>	
Disable sensor power output <small>Sensor is powered from another source (JB40POW)</small>	<input checked="" type="checkbox"/>	
Buzzer Option	Off	

In addition add vessel parameters, IMO number, Bottom sensor type and Bottom equipment Serial number (If these are not entered you will get reminders on startup or exit of the system setup screen)

13.2 Popups

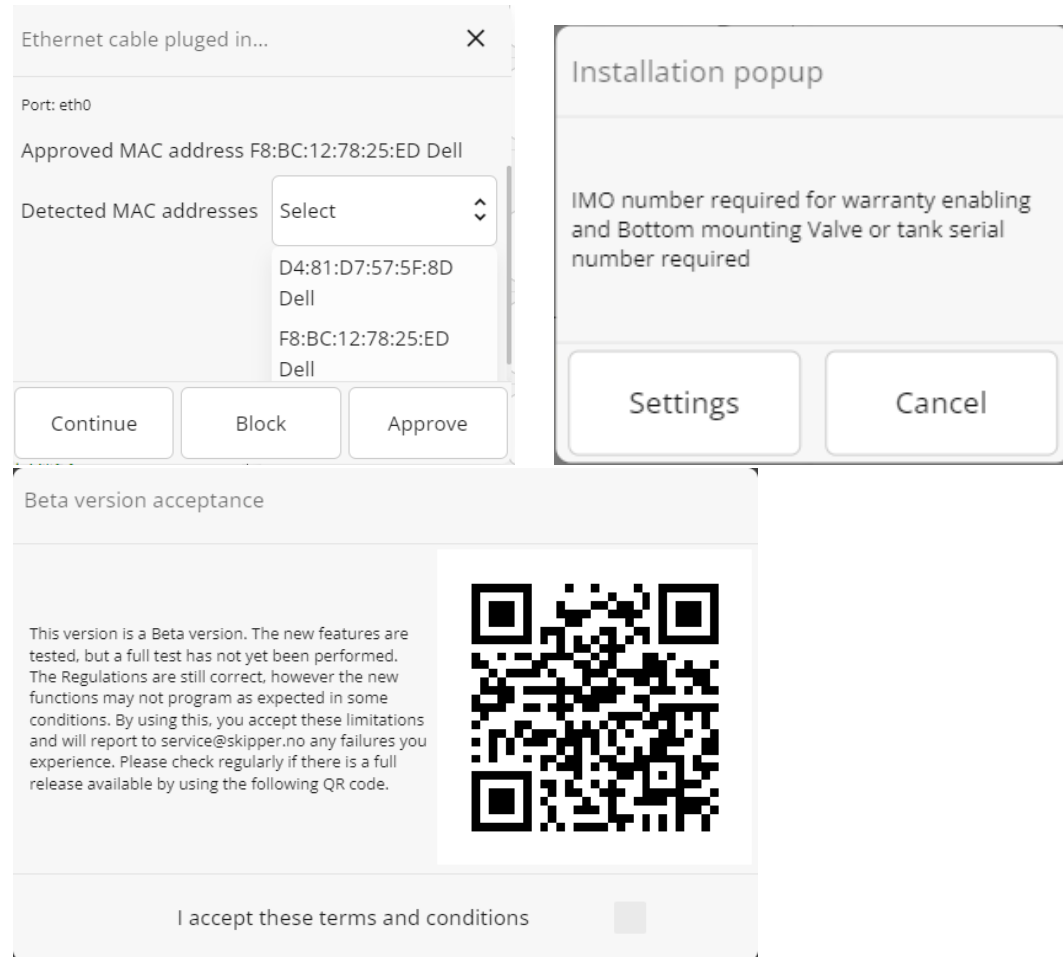

Popups on startup.

You may get the following:

Beta Version approval – Accept terms and close the popup (Check for updates using QR code)

Foreign network – Select a safe point in the network to allow the system to detect unauthorized cable being plugged into the system, Approve this. (one for each Network port)

IMO number – This system registers the vessels IMO number or Vessel name, for service purposes.

Bottom equipment – Follow the link to enter the Sensor type in use, and the bottom equipment (valve or Tank number serial number)

13.3 Input/ output

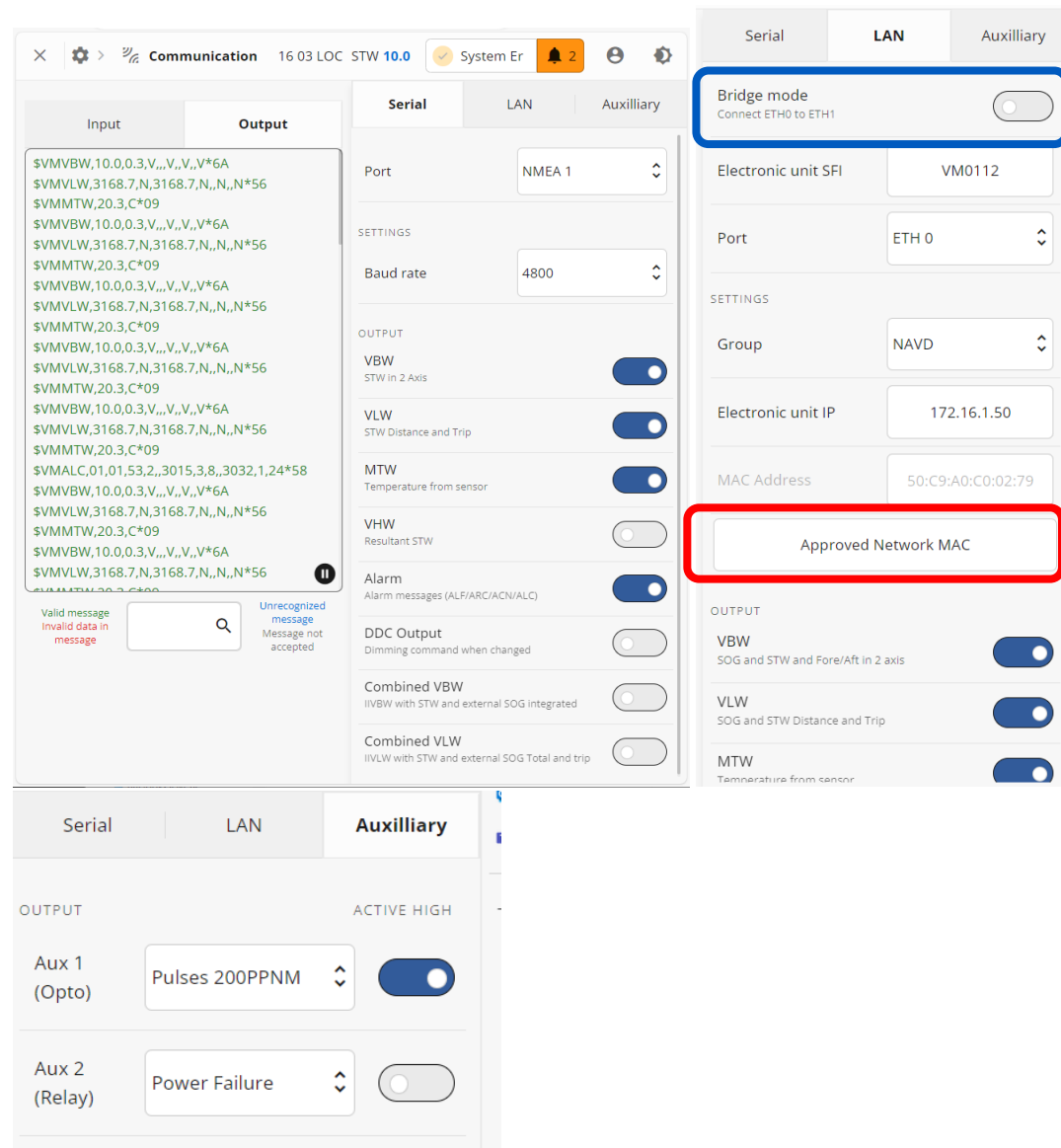

Serial

In Communications setup, Configure the IO as required.

Select the outputs required, and the Baud rate for the 2 serial ports (NMEA/IEC61162-1)

Ethernet

2 Ethernet ports using IEC61162-450 and supporting IEC-61162-460

Network is Blocked on startup, Select a safe IP address on your networks (usually router or switch) and register this using the popup **or Approved Network MAC**

This is to ensure foreign networks are detected. Networks should have different subnets.

Select an IP is the networks subnet, different subnets for each port.

If both ports are to be used in the same subnet (switch) activate **Bridge Mode** (Admin only) In this case ETH0 Will define the IP/ Subnet

Aux output function (Connector X6) can be selected here

13.4 Alerts

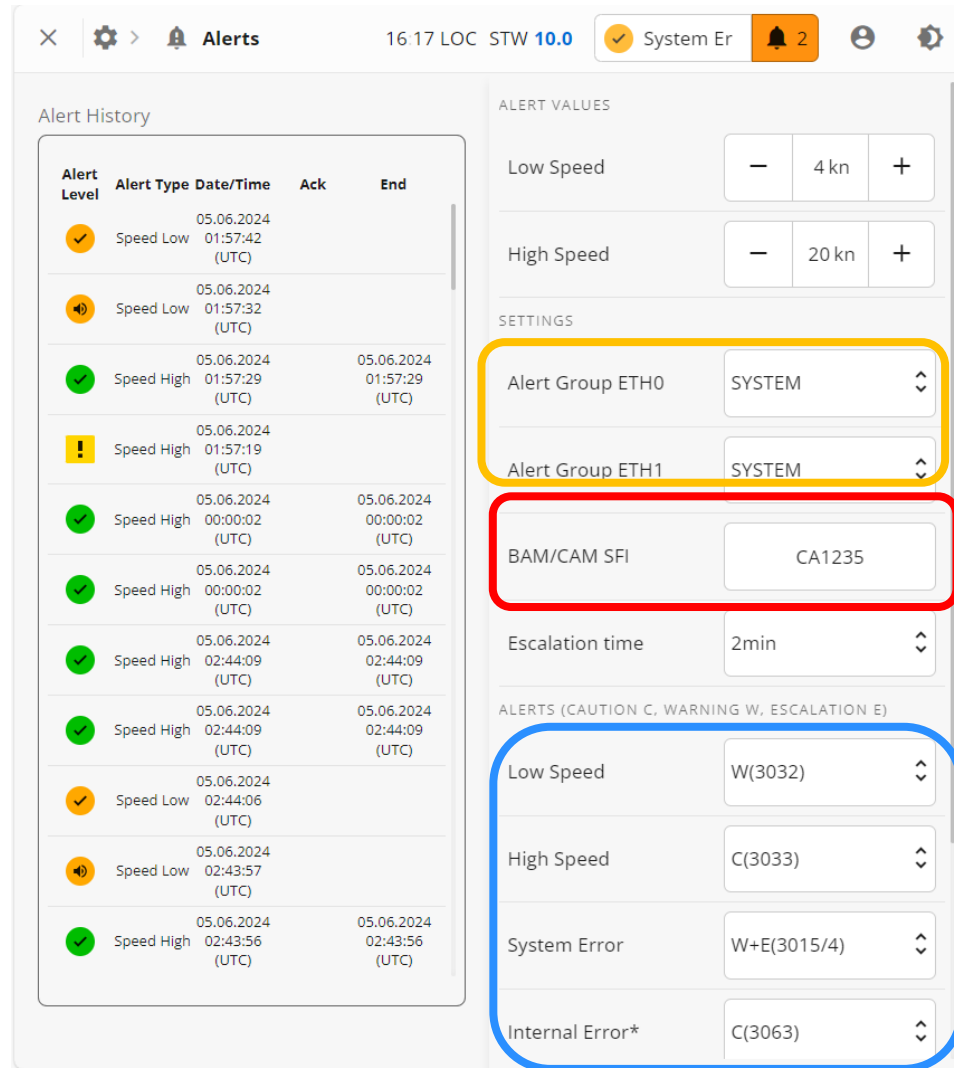

Alert History

Alert Level	Alert Type	Date/Time	Ack	End
✓	Speed Low	05.06.2024 01:57:42 (UTC)		
🔊	Speed Low	05.06.2024 01:57:32 (UTC)		
✓	Speed High	05.06.2024 01:57:29 (UTC)	05.06.2024 01:57:29 (UTC)	
!	Speed High	05.06.2024 01:57:19 (UTC)		
✓	Speed High	05.06.2024 00:00:02 (UTC)	05.06.2024 00:00:02 (UTC)	
✓	Speed High	05.06.2024 00:00:02 (UTC)	05.06.2024 00:00:02 (UTC)	
✓	Speed High	05.06.2024 02:44:09 (UTC)	05.06.2024 02:44:09 (UTC)	
✓	Speed High	05.06.2024 02:44:09 (UTC)	05.06.2024 02:44:09 (UTC)	
✓	Speed Low	05.06.2024 02:44:06 (UTC)		
🔊	Speed Low	05.06.2024 02:43:57 (UTC)		
✓	Speed High	05.06.2024 02:43:56 (UTC)	05.06.2024 02:43:56 (UTC)	

ALERT VALUES

Low Speed: 4 kn

High Speed: 20 kn

SETTINGS

Alert Group ETH0: SYSTEM

Alert Group ETH1: SYSTEM

BAM/CAM SFI: CA1235

Escalation time: 2min

ALERTS (CAUTION C, WARNING W, ESCALATION E)

Low Speed: W(3032)

High Speed: C(3033)

System Error: W+E(3015/4)

Internal Error*: C(3063)

The system has alerts, these are not obligatory in most installations (check class regulations)

These can be disabled, or they can be given different categories. (Off, Caution, Warning, W+Escalation)

Connect the CAM/BAM system by defining the Alert group

Connect to the CAM/BAM SFI.

Alternatively connect to the NMEA input and output.

Activate the IO that will communicate with the Alarm system

Power failure can also be detected using one of the Aux output 2 (relay)

Test the alerts, using the Test Alerts button in Diagnostics page (See HAT, next section)

13.5 Harbour Acceptance Test (HAT)

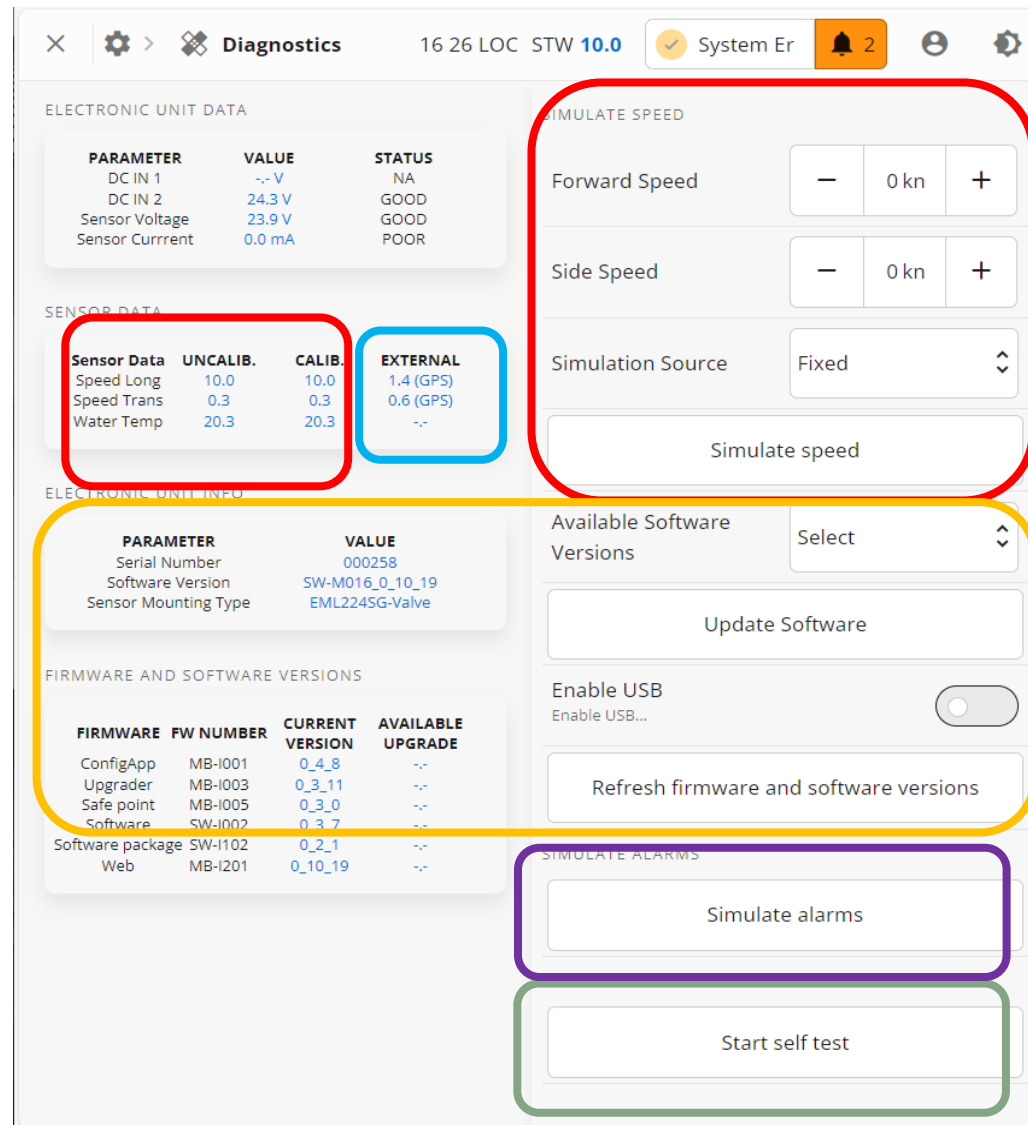

ELECTRONIC UNIT DATA

PARAMETER	VALUE	STATUS
DC IN 1	-- V	NA
DC IN 2	24.3 V	GOOD
Sensor Voltage	23.9 V	GOOD
Sensor Current	0.0 mA	POOR

SENSOR DATA

Sensor Data	UNCALIB.	CALIB.	EXTERNAL
Speed Long	10.0	10.0	1.4 (GPS)
Speed Trans	0.3	0.3	0.6 (GPS)
Water Temp	20.3	20.3	--

ELECTRONIC UNIT INFO

PARAMETER	VALUE
Serial Number	000258
Software Version	SW-M016_0_10_19
Sensor Mounting Type	EML224SG-Valve

FIRMWARE AND SOFTWARE VERSIONS

FIRMWARE	FW NUMBER	CURRENT VERSION	AVAILABLE UPGRADE
ConfigApp	MB-I001	0_4_8	--
Upgrader	MB-I003	0_3_11	--
Safe point	MB-I005	0_3_0	--
Software	SW-I002	0_3_7	--
Software package	SW-I102	0_2_1	--
Web	MB-I201	0_10_19	--

SIMULATE SPEED

Forward Speed: [-] 0 kn [+]

Side Speed: [-] 0 kn [+]

Simulation Source: Fixed [v]

[Simulate speed]

AVAILABLE SOFTWARE VERSIONS

Select [v]

[Update Software]

Enable USB: [Enable USB...] [toggle]

[Refresh firmware and software versions]

SIMULATE ALARMS

[Simulate alarms]

[Start self test]

To show or prove the system works you can do the following:

- 1. Test Sensor display**
Set a speed and Run a fixed speed simulation ' Simulate speed'
- 2. Software**
Check the system is updated to the latest software, if not, download from www.skipper.no to a USB, and perform upgrade.
- 3. Test IO**
Look at Connected systems, Conning/BAM/VDR/Repeaters, and check the correct formats are coming, alternatively, check the communications terminal input and output.
Check the desired inputs are connected. Usually
- GPS (strongly recommended)
Heading (recommended)
- 4. Test Alerts**
Use the Simulate alarms to trigger all the active alarms, use the BAM to remotely acknowledge.
- 5. Self test**
Run the self test for an internal check of the system

Self Test

13.6 Self Test

SELF-TEST INFO				
TEST NUMBER	TEST PERFORMED	RESULTS	LIMIT	STATUS
1	CPU Load	9.55 %	70.00 %	PASS
2	RAM Usage	28.95 %	90.00 %	PASS
3	ETH0 Load	0.06 Mb/s	50.00 Mb/s	PASS
4	ETH1 Load	0.00 Mb/s	50.00 Mb/s	PASS
5	DCIN 1	0.00 V	18-31 V	FAIL
6	DCIN 2	24.26 V	18-31 V	PASS
7	Sensor Voltage	24.06 V	18-31 V	PASS
8	Sensor Current	0.00 mA	10-200 mA	FAIL
9	Calibration Stability	8.51 kn	3.00 kn	FAIL
10	Sensor Stability	0.00 kn	1.00 kn	PASS
11	Cleaning Status	6.97	0.50	GOOD

Self test will test the internal parameters and connections of the system

CPU load

How much the system is doing
RAM useage – How much memory is in use

Ethernet Load

If too high the system may slow down

Sensor output voltage/Current

The sensor is connected correctly* (if not, a system error will also show)

Calibration stability

After calibration and sailing, how much is the calibration wrong over time

Sensor stability,

How much the data jumps from the sensor

Cleaning status.

If the sensor measures much less than the GPS then the system probably needs cleaning

NORWAY/HEADQUARTER

Jotron AS
Ringdalskogen 8
3270 Larvik, Norway
Tel: +47 33 13 97 00

NORWAY / JOTRON SKIPPER

Jotron SKIPPER AS
Enebakkveien 150
0680 Oslo, Norway
Tel: +47 22 30 22 70

SINGAPORE

Jotron Asia Pte. Ltd.
10 Ubi Crescent, Ubi Techpark
Lobby B, #05-11/12, Singapore 408564
Tel: +65 65 42 63 50

CHINA

Norway Jotron AS Beijing
Representative Office (ATC business)
No.1 building, No.88 yard,
Jindai road, Haidian district,
Beijing, China, 100095

UK

Jotron UK Ltd.
Crosland Park, Cramlington
NE23 1LA, UK
Tel: +44 1670 712000

USA

Jotron USA, Inc
6300 Rothway Street, Suite C
Houston, TX 77040, USA
Tel: +1 713 268 1061

LITHUANIA

UAB Jotron
Juozapavičiaus 21b, LT-45256
Kaunas, Lithuania
Tel: +370 37 338233